

## Modbus I/O

**I/O Slaves:** FGR3-IOS-C-U  
FGRIO-S  
FGR2-IOS-C-U  
FGR2-IOS-CE-U  
I2-IOS

**I/O Expansion  
Radio Base:** FGR3-IO-IOE  
FGR2-IO-IOE

## User Manual and Reference Guide



Part Number: LUM0010AC

Revision: April-2024



## Warranty

FreeWave Technologies, Inc. warrants your FreeWave® Wireless Data Radio against defects in materials and manufacturing for a period of three years from the date of shipment, depending on model number. In the event of a Product failure due to materials or workmanship, FreeWave will, at its discretion, repair or replace the Product. For evaluation of Warranty coverage, return the Product to FreeWave upon receiving a Return Material Authorization (RMA).

In no event will FreeWave Technologies, Inc., its suppliers, or its licensors be liable for any damages arising from the use of or inability to use this Product. This includes business interruption, loss of business information, or other loss which may arise from the use of this Product. OEM customer's warranty periods can vary.

Warranty Policy will **not apply** in the following circumstances:

1. If Product repair, adjustments, or parts replacements are required due to accident, neglect, or undue physical, electrical, or electromagnetic stress.
2. If Product is used outside of FreeWave specifications as stated in the Product's data sheet.
3. If Product has been modified, repaired, or altered by Customer unless FreeWave specifically authorized such alterations in each instance in writing. This includes the addition of conformal coating.

## Special Rate Replacement Option

A special rate replacement option is offered to non-warranty returns or upgrades. The option to purchase the replacement unit at this special rate is only valid for that RMA. The special replacement rate option expires if not exercised within 30 days of final disposition of RMA.

## Safety Information

---



**Warning!** Do NOT remove or insert diagnostics cable while circuit is live.

---

FreeWave Technologies, Inc.  
5395 Pearl Pkwy, Ste. 100  
Boulder, CO 80301  
303.381.9200  
Toll Free: 1.866.923.6168  
Fax: 303.786.9948

Printed in the United States of America.  
Copyright © 2015 by FreeWave  
Technologies, Inc. All rights reserved.

[www.freewave.com](http://www.freewave.com)

## Export Notification

FreeWave Technologies, Inc. products may be subject to control by the Export Administration Regulations (EAR) and/or the International Traffic in Arms Regulations (ITAR). Export, re-export, or transfer of these products without required authorization from the U.S. Department of Commerce, Bureau of Industry and Security, or the U.S. Department of State, Directorate of Defense Trade Controls, as applicable, is prohibited. Any party exporting, re-exporting, or transferring FreeWave products is responsible for obtaining all necessary U.S. government authorizations required to ensure compliance with these and other applicable U.S. laws. Consult with your legal counsel for further guidance.

## FCC Notifications

This device complies with part 15 of the FCC rules. Operation is subject to the following two conditions: 1) This device may not cause harmful interference and 2) this device must accept any interference received, including interference that may cause undesired operation.

The content of this guide covers FreeWave Technologies, Inc. models sold under FCC ID: FCC ID KNY-6231812519 (FGR2 models) and FCC ID: FCC ID KNY-FGR3 (FGR3 models).

### FCC

All models sold under the FCC ID(s) listed above must be installed professionally and are only approved for use when installed in devices produced by FreeWave Technologies or third-party OEMs with the express written approval of FreeWave Technologies, Inc. Changes or modifications should not be made to the device.



**Warning!** The FGR3-IO-C-U, FGR3-IO-IOE, FGR2-IO-C-U, FGR2-IO-CE-U, and FGR2-IO-IOE models have a maximum transmitted output power of 1 W. The antennas used must provide a separation distance of at least 23 cm from all persons and must not be co-located or operate in conjunction with any other antenna or transmitter.



**Warning!** The FGRIO-S model has a maximum transmitted output power of 100 mW. The antennas used must provide a separation distance of at least 23 cm from all persons and must not be co-located or operate in conjunction with any other antenna or transmitter.

---

## FCC NEMA Installation and Label

Where applicable, the models described in this guide must be installed in a NEMA enclosure. When any FreeWave Technologies, Inc. module is placed inside an enclosure, a label must be placed on the outside of the enclosure. The label must include the text "**Contains FCC ID: FCC ID KNY-6231812519 (FGR models) and contains FCC ID: FCC ID KNY-FGR3 (FGR3 models).**"

## IC Notifications

This device complies with Industry Canada license-exempt RSS standard(s). Operation is subject to the following two conditions: (1) this device may not cause interference, and (2) this device must accept any interference, including interference that may cause undesired operation of the device.

*Ce dispositif est conforme aux normes permis-exemptes du Canada RSS d'industrie. L'opération est sujette aux deux conditions suivantes : (1) ce dispositif peut ne pas causer l'interférence, et (2) ce dispositif doit accepter n'importe quelle interférence, y compris l'interférence qui peut causer le fonctionnement peu désiré du dispositif.*

## GNU License Notification

Some of the software in the firmware is licensed under the GNU General Public License and other Open Source and Free Software licenses. You can obtain corresponding source by contacting FreeWave and requesting the source on CD.

## Restricted Rights

Any product names mentioned in this manual may be trademarks or registered trademarks of their respective companies and are hereby acknowledged.

This manual is only for use by purchasers and other authorized users of FreeWave products.

No part of this manual may be reproduced or transmitted in any form or by any means, electronic or mechanical, or for any purpose without the express written permission of FreeWave Technologies, Inc. FreeWave reserves the right to make changes to this manual without notice. FreeWave assumes no responsibility or liability for the use of this manual or the infringement of any copyright or other proprietary right.

### UL Notifications



Models FGR3-IOS-C-U, FGRIO-S, FGR2-IOS-C-U, FGR2-IOS-CE-U, FGR3-IO-IOE, FGR2-IO-IOE, I2-IOM-U, and I2-IOS-C-U are suitable for use

in Class I, Division 2, Groups A, B, C, and D or non-hazardous locations only. Do not connect or disconnect any connectors while the circuit is live unless the area is known to be non-hazardous.



**Warning! EXPLOSION HAZARD** - Substitution of components may impair suitability for Class1, Division2.



**Warning! DO NOT REMOVE** or insert the diagnostics cable while the circuit is live unless the area is known to be free of ignition concentrations or flammable gases and vapors.

***Avertissement:** NE PAS RETIRER ni insérer le câble de diagnostic lorsque le circuit est sous tension, à moins que la zone ne soit connue pour être exempte de concentrations inflammables ou de gaz et vapeurs inflammables.*



**Warning!** Where applicable, the models described in this guide must be installed in a tool secured and suitable Type rated enclosure

***Avertissement:** Le cas échéant, les modèles décrits dans ce guide doivent être installés dans un boîtier sécurisé par un outil et adapté.*



**Warning!** The models described in this guide, with and without casing, must be installed in another tool secured, and Type 3 or better enclosure suitable for area of installation.

***Avertissement!** .Les modèles décrits dans ce guide, avec et sans boîtier, doivent être installés dans un autre outil sécurisé et dans un boîtier de type 3 ou supérieur adapté à la zone d'installation.*

- Input voltage for the FGR3-IOS-C-U, FGR2-IOS-C-U, FGR2-IOS-CE-U, FGR3-IO-IOE, FGR2-IO-IOE, is +6.0 to +30.0 VDC.
- Input voltage for the FGRIO-S is +6.0 to +20.0 VDC.
- Input voltage for the I2-IOS-C-U is +6.0 to +30.0 VDC.

**Important!:** Input power shall be derived from a single Class 2 power source.

### **ATEX Certification**

- Provision shall be made to prevent the rated voltage being exceeded by the transient disturbances of more than 140% of the peak rated voltage.
- The system shall be mounted in an ATEX certified enclosure with a minimum ingress protection rating of at least IP54 as defined in EN60529 and used in an environment of not more than pollution degree 2.
- The enclosure must have a door or cover accessible only by the use of a tool.

## Table of Contents

<b>Preface</b> .....	<b>14</b>
1.1 I/O Product Family .....	19
1.2 Modbus I/O Systems .....	21
1.3 Configuration Tool Options .....	22
1.4 Tool Suite and Terminal Emulators.....	22
1.5 Radio Setup Mode.....	23
1.5.1 Using Tool Suite to Connect to and Program Radios .....	23
1.5.2 Accessing the Setup Menu Using a Terminal Emulator.....	24
View the Setup menu in Board-level Radios.....	26
1.6 LED Indications .....	27
2. Configuring a Serial Master .....	29
2.1 Configuring a Serial Master .....	30
2.2 Setting the Serial Master's Role in the Network .....	31
2.3 Establishing Communication Between the Serial Master's Data Port and an End Device .....	31
2.3.1 Baud Rate .....	31
2.3.2 Data Parity.....	32
2.3.3 Flow Control .....	34
2.3.4 Modbus RTU .....	34
2.3.5 Serial Interface .....	35
2.3.6 Setup Port .....	35
2.3.7 Turn Off Delay .....	36
2.3.8 Turn On Delay .....	37
2.3.9 Use Break to Access Setup .....	37
2.4 Establishing Communication with Modbus I/O Slaves .....	37
2.5 Setting Serial Master RF Transmission Characteristics .....	38
2.5.1 Frequency Key .....	38
2.5.2 Max Packet Size and Min Packet Size.....	39
2.6 Setting Serial Master MultiPoint Parameters.....	40
2.6.1 Master Packet Repeat .....	40
2.6.2 Repeaters.....	42
2.6.3 Subnet ID - Serial Master .....	42
3. Configuring a Modbus I/O Slave .....	43
3.1 Configuring a Modbus I/O Slave .....	44
3.2 Modbus I/O Slaves in Tool Suite.....	46

3.3	Setting the Modbus I/O Slave's Role in the Network .....	46
3.4	Establishing Communication Between the Modbus I/O Slave and an End Device .....	46
3.5	Establishing Communication with the Serial Master.....	48
3.6	Modbus I/O Slave RF Transmission Characteristics .....	48
3.7	Modbus I/O Slave MultiPoint Parameters .....	48
3.8	Modbus I/O Slave Modbus Parameters .....	49
3.8.1	AI1 User Offset and AI2 User Offset.....	49
3.8.2	AI1 250 Ohms and AI2 250 Ohms .....	49
3.8.3	AO1 Custom Offset and AO2 Custom Offset.....	50
3.8.4	AO1 Unchanged and AO2 Unchanged .....	50
3.8.5	AO1 Default CMD and AO2 Default CMD.....	50
3.8.6	Clear Counter 1 on Read and Clear Counter 2 on Read.....	51
3.8.7	Clip AI1 Offset at Zero and Clip AI2 Offset at Zero .....	51
3.8.8	Counting Mode .....	52
3.8.9	Default Delay.....	53
3.8.10	DI1 125 Ohms and DI2 125 Ohms.....	53
3.8.11	DI1 Pullup and DI2 Pullup.....	54
3.8.12	DI1 Counter Edge and DI2 Counter Edge.....	55
3.8.13	Digital Output 1 Default and Digital Output 2 Default .....	55
3.8.14	DO Bi-Stable .....	55
3.8.15	DO Monostable Time.....	56
3.8.16	Fast AI (DI1) and Fast AI (DI2) .....	56
3.8.17	Modbus Mode - Modbus I/O Slave .....	57
3.8.18	Modbus Address Size - Modbus I/O Slave.....	57
3.8.19	Modbus ID - Modbus I/O Slave.....	57
3.8.20	Sensor Power Default.....	58
4.	Other Radio Settings .....	60
4.1	Setting Other RF Transmission Characteristics .....	60
4.1.1	Frequency Zones - 900MHz .....	60
	Enable Frequency Zones in Tool Suite .....	62
	Enable Frequency Zones in the Terminal Interface.....	62
4.1.2	Hop Table Size - 900MHz.....	63
4.1.3	Hop Table Version - 900MHz.....	64
4.1.4	High Noise.....	65
4.1.5	Low Power Mode .....	65
4.1.6	MCU Speed.....	67
4.1.7	Remote LED.....	67



4.1.8	Retry Timeout.....	68
4.1.9	RTS to CTS.....	68
4.1.10	Slave Security.....	70
4.1.11	Transmit Power.....	70
4.1.12	Transmit Rate.....	71
4.2	Setting Other MultiPoint Parameters.....	71
4.2.1	1 PPS Enable Delay.....	72
	Setup 1PPS Enable/Delay.....	72
	Calibrate an I/O Slave in 1PPS Enable/Delay Mode.....	72
4.2.2	Diagnostics.....	73
4.2.3	DTR Connect.....	73
4.2.4	Local Mode.....	74
4.2.5	Max Slave Retry.....	74
4.2.6	Multi-Master Sync.....	74
4.2.7	Radio ID.....	74
4.2.8	Radio Name.....	75
4.2.9	Repeater Frequency.....	75
4.2.10	Retry Odds.....	75
4.2.11	Slave/Repeater.....	76
4.3	Reading Diagnostics in Tool Suite.....	76
5.	Installing and Wiring Components.....	78
5.1	Wiring Modbus I/O Slaves.....	78
5.1.1	Radio Power.....	78
5.1.2	Digital Inputs.....	78
5.1.3	Digital Outputs.....	79
5.2	Wiring Modbus I/O Slaves to 4-20 mA Sensors.....	79
5.2.1	Connecting a 4-20 mA Sensor to Analog Input 1 or Analog Input 2.....	79
5.2.2	Connecting a 4-20 mA Sensor to Analog Input 3 or Analog Input 4.....	81
5.3	Wiring Modbus I/O Slaves to 1-5 V Sensors.....	83
5.3.1	Connecting a 1-5 Volt Sensor to Analog Input 1 or Analog Input 2.....	83
5.3.2	Connecting 1-5 Volt Sensor to Analog Input 3 or Analog Input 4.....	84
5.3.3	1-5 Volt Sensor Signal Coupling for Analog Input 3 and Analog Input 4.....	84
5.4	Using an Analog Input as a Digital Input with a Pullup Resistor.....	86
5.5	Plunger Lift Example.....	88
5.5.1	Modbus I/O Slave to the Well Head.....	88
5.5.2	Modbus Registers.....	90
5.6	Tank Level Example.....	91

5.6.1	Modbus I/O Slave to the Well Head .....	91
5.6.2	Modbus Registers.....	91
5.7	Tubing Pressure Example .....	92
5.7.1	I/O Master to the RTU .....	92
5.7.2	I/O Slave to the Well Head .....	92
5.7.3	Terminal Port Mappings in Tool Suite .....	93
6.	Viewing Radio Statistics.....	94
6.1	Viewing the Radio Statistics in Tool Suite .....	94
6.2	Viewing the Radio Transmission Characteristics in the Terminal Interface .....	94
6.3	Antenna Reflected Power .....	95
6.4	Master-Slave Distance.....	95
6.5	Noise Level.....	95
6.6	Number of Disconnects .....	96
6.7	Radio Temperature.....	96
6.8	Rate % .....	96
6.9	Signal Level.....	97
6.10	Transmit Current.....	97
7.	Modbus Register Map.....	98
7.1	Modbus I/O Slave Register Map .....	99
7.2	Coil Descriptions.....	111
7.2.1	1 DO1; DISCRETE OUTPUT #1.....	111
7.2.2	2 DO2; DISCRETE OUTPUT #2.....	111
7.2.3	3 SENSOR POWER.....	111
7.2.4	4 SENSOR POWER-ON DEFAULT .....	111
7.2.5	5 DO1 FAULT.....	111
7.2.6	6 DO2 FAULT.....	111
7.2.7	7 SENSOR POWER FAULT.....	112
7.2.8	8 COMM FAIL FAULT LATCH.....	112
7.2.9	9 CLEAR COUNTER 1 ON READ .....	112
7.2.10	10 CLEAR COUNTER 2 ON READ .....	112
7.2.11	11 COUNTER1 INC ON 0-1 EDGE .....	112
7.2.12	12 COUNTER2 INC ON 0-1 EDGE .....	113
7.2.13	13 DO1 LEAVE UNCHANGED.....	113
7.2.14	14 DO2 LEAVE UNCHANGED.....	113
7.2.15	15 DO1 DEFAULT STATE .....	113
7.2.16	16 DO2 DEFAULT STATE .....	113
7.2.17	17 COUNTER1 INC LATCH.....	113

7.2.18 18 COUNTER2 INC LATCH ..... 113

7.2.19 19 COUNTER1 CLEAR ..... 113

7.2.20 20 COUNTER2 CLEAR ..... 113

7.2.21 21 AI1 OFFSET CLIP AT 0 ..... 114

7.2.22 22 AI2 OFFSET CLIP AT 0 ..... 114

7.2.23 25 DI1 PULLUP ..... 114

7.2.24 26 DI2 PULLUP ..... 114

7.2.26 28 AO1/VSNS LEAVE UNCHANGED ..... 115

7.2.27 29 AO2 LEAVE UNCHANGED ..... 115

7.2.28 30 DEBOUNCE COUNTERS ..... 115

7.2.29 31 FILTER COUNTERS ..... 115

7.2.30 32 RESET RADIO ..... 115

7.2.31 33, 34 FAST AI(DI1)/FAST AI(DI2) ..... 115

7.2.32 35, 36 DI1/DI2 PULLUP ACTIVE ..... 115

7.2.33 37,38 AI1 AI2 250 OHM PD ACTIVE ..... 116

7.2.34 39, 40 DI1 125 OHM PD ACTIVE ..... 116

7.2.35 45, 46 AI1/AI2 250 OHM PD FAULT ..... 116

7.2.36 47, 48 DI1/DI2 125 OHM PD FAULT ..... 116

7.3 Discrete Input Descriptions ..... 116

7.3.1 10003 DI OF AI1 ..... 116

7.3.2 10003 DI OF AI1 ..... 116

7.3.3 10003 DI OF AI1 ..... 116

7.3.4 10004 DI OF AI2 ..... 117

7.4 Holding Register Descriptions ..... 117

7.4.1 40001 ALL COILS 16:1 READ ONLY ..... 117

7.4.2 40002 ALL COILS 32:17 READ ONLY ..... 117

7.4.4 40004 AI1 USER OFFSET ..... 117

7.4.5 40005 AI2 USER OFFSET ..... 117

7.4.6 40006 DO MONOSTABLE TIME ..... 118

7.5 Input Register Descriptions ..... 118

7.5.1 30001 AI2 LSW ..... 118

7.5.2 30002 AI2 LSW ..... 118

7.5.3 30003 AI2 LSW ..... 119

7.5.4 30004 AI2 LSW ..... 119

7.5.5 30005 DI1 COUNTER MSW ..... 119

7.5.6 30006 DI1 COUNTER LSW ..... 119

7.5.7 30007 DI2 COUNTER MSW ..... 119

7.5.8	30008 DI2 COUNTER LSW.....	119
7.5.9	30009 VBATT.....	119
7.5.10	30009 VBATT.....	119
7.5.11	30011 ALL DIs.....	120
7.5.12	30012 ALL COILS 16:1.....	120
7.5.13	30013 ALL COILS 32:17.....	120
7.5.14	30014 AI1 MSW Offset Result.....	120
7.5.15	30015 AI2 MSW Offset Result.....	120
7.5.16	30016 AI(DI1).....	120
7.5.17	30017 AI(DI1).....	121
7.5.18	30018, 30019 AI1 SHORT FLOAT.....	121
7.5.19	30020, 30021 AI1 SHORT FLOAT.....	121
7.5.20	30022, 30023 AI(DI1) SHORT FLOAT.....	121
7.5.21	30024, 30025 AI(DI2) SHORT FLOAT.....	121
7.5.22	30026, 30027 VBATT SHORT FLOAT.....	121
7.5.23	30028, 30029 DEGC SHORT FLOAT.....	121
7.5.24	30030 DO1/DO2 CURRENT.....	121
7.5.25	30034 ALL COILS 33:48.....	121
7.5.26	30038 DISCRETE IN 1:16.....	122
8.	Specifications.....	123
8.1	FGR2-IO-IOE Specifications.....	124
8.2	FGR2-IOS-C-U and FGR2-IOS-CE-U Specifications.....	127
8.3	FGRIO-S Specifications.....	130
8.4	I2-IOS-C-U Specifications.....	132
8.5	FGR3-IO-IOE Specifications.....	134
8.6	FGR3-IOS-C-U Specifications.....	137
9.	Ports.....	140
9.1	FGR2-IO-IOE and FGR3-IO-IOE Ports.....	141
9.2	FGR2-IOS-CE-U Ports.....	142
9.3	FGR3-IOS-C-U Ports.....	143
9.4	FGR2-IOS-C-U Ports.....	144
9.5	FGRIO-S Ports.....	145
10.	Terminal Block Layouts.....	147
10.1	FGR3-IOS-C-U, FGRIO-S, FGR2-IOS-C-U, FGR2-IOS-CE-U, I2-IOS, FGR3-IO-IOE, and FGR2-IO-IOE Terminal Block Layouts.....	148
	Appendix A: DI of AI1 Pull-Up Resistor Network.....	150
	Appendix B: Troubleshooting Terminal Emulators.....	152
	Appendix C: Frequently Asked Questions.....	154



This manual provides information specifically about using FreeWave serial Master, I/O Saves, and serial Slaves in Modbus mode, and covers these models:

I/O Slaves	I/O Expansion Radio Base
<ul style="list-style-type: none"><li>• FGR3-IOS-C-U (board level)</li><li>• FGRIO-S (board level)</li><li>• FGR2-IOS-C-U (board level)</li><li>• FGR2-IOS-CE-U (enclosed)</li></ul>	<ul style="list-style-type: none"><li>• FGR3-IO-IOE (enclosed)</li><li>• FGR2-IO-IOE (enclosed)</li></ul>

**Note:** If using these devices in a wire replacement I/O system, see the LUM0008AG Wire Replacement IO User Manual.

This document includes this information about setting up a Modbus I/O system:

- A basic introduction to both wire replacement and Modbus I/O, to help determine the correct application.
- Radio configuration including:
  - An introduction to the configuration tools.
  - How to access configuration parameters.
  - I/O Master and I/O Slave specific setup.
  - Additional radio communication settings.
- Installation and basic wiring diagrams.
- Terminal block usage information and terminal block diagrams.

## Additional Information

- Application Note #5499: Adding I/O Points with FGR2-IO-IOE in Serial Modbus Slave Operating Mode. Please refer to this document for FGR3-IO-IOE and reference FGR2-IO-IOE in place of.
- LUM0008AG Wire Replacement I/O User Manual: Using the I/O radio family in a wire replacement I/O system.
- LUM0017AB I/O Expansion User Manual: Expanding the number of I/O ports available on an I/O Slave.

## Contacting FreeWave Technical Support

For up-to-date troubleshooting information, check the **Support** page at [www.freewave.com](http://www.freewave.com). FreeWave provides technical support Monday through Friday, 8:00 AM to 5:00 PM Mountain Time (GMT -7).

- Call toll-free at 1.866.923.6168.
- In Colorado, call 303.381.9200.
- Contact us through e-mail at [moreinfo@freewave.com](mailto:moreinfo@freewave.com).

## Printing this Document

This document is set to print double-sided with a front cover and a back cover. Viewing this document online with a PDF viewer, may show pages intentionally left blank to accommodate the double-sided printing.

## Document Styles

This document uses these styles:

- FreeWave applications appear as: **FreeWave**.
- Parameter setting text appears as: **[Page=radioSettings]**
- File names appear as: **configuration.cfg**.
- File paths appear as: **C:\Program Files (x86)\FreeWave Technologies**.
- User-entered text appears as: **xxxxxxxxxx**.
- 3<sup>rd</sup>-party names appear as: **Notepad®**.



**Caution:** Indicates a situation that **MAY** cause damage to personnel, the radio, data, or network.

**Example:** Provides example information of the related text.

**FreeWave Recommends:** Identifies FreeWave recommendation information.

---

**Important!:** Provides semi-cautionary information relevant to the text or procedure.

---

**Note:** Emphasis of specific information relevant to the text or procedure.

---



**Tip:** Provides time saving or informative suggestions about using the product.

---



**Warning!** Indicates a situation that **WILL** cause damage to personnel, the radio, data, or network.

---

## Documentation Feedback

Send comments or questions about this document's content to [techpubs@freewave.com](mailto:techpubs@freewave.com). In the email, include the title of the document or the document's part number and revision letter (found in the footer).





---

## 1. Introduction

Wireless I/O communication is applicable in multiple industries including oil and gas, waste water management, irrigation, and utilities.

**Example:** Use wireless I/O communication to monitor multi-well pad sites and underground storage capacity, control plunger lift, control lift stations and water quality, or report on groundwater use.

Wireless I/O provides a cost effective, accurate, and reliable solution for application monitoring and control needs.

FreeWave radios provide these I/O interfaces:

- **Wire Replacement** - Provides an alternative in situations where running wires is costly or not possible.
  - Connect a FreeWave I/O Master radio to a PLC or RTU device.
  - Connect FreeWave I/O Slave radios to sensors, transmitters, and switches to monitor and control devices.
- **Modbus I/O** - A Modbus I/O system provides an alternative to running wires, but also takes advantage of Modbus Polling capabilities to monitor, configure, and control a device.

This document describes how to setup FreeWave radios for use in a **Modbus I/O** system.

**Note:** For information about setting up FreeWave radios for use in a wire replacement I/O system, see the **LUM0008AG Wire Replacement IO User Manual**.

## 1.1 I/O Product Family

The FreeWave I/O product family consists of products for both signal replication (wire replacement I/O) and Modbus I/O integrations, including the ability to expand the number of inputs and output available using expansion modules.

Model	Description	Wire Replacement I/O	Modbus I/O
<b>I/O Slaves</b>			
FGR3-IO-C-U	<ul style="list-style-type: none"> <li>In the Modbus mode, FGR3-IO-C-U models can be directly connected as an I/O peripheral to a SCADA network.</li> </ul>		x
FGR2-IO-C-U FGR2-IO-CE-U	<ul style="list-style-type: none"> <li>In the Modbus mode, FGR2-IO-C-U models can be directly connected as an I/O peripheral to a SCADA network. In wire replacement I/O (wireless signal replication), the FGR2-IO-C-U models can operate as a Slaves linked to an FGRIO-M (Master) radio.</li> <li>The FGR2-IO-CE-U version includes internal switchable and protected resistors for convenience when using 4-20 mA sensors.</li> </ul>	x	x
FGR3-IO-IOE	<ul style="list-style-type: none"> <li>A radio base that supports adding expansion modes in a Modbus I/O system.</li> <li>In the Modbus mode, FGR3-IO-IOE models can be directly connected as an I/O peripheral to a SCADA network.</li> </ul>		x
FGR2-IO-IOE	<ul style="list-style-type: none"> <li>A radio base that supports adding expansion modes in a Modbus I/O system.</li> <li>In Modbus mode the FGR2-IO-IOE can provide wireless I/O to a SCADA network. In wire replacement, the FGR2-IO-IOE can operate as a Slave linked to an FGRIO-M (Master).</li> </ul>	x	x

I/O Master			
FGRIO-M	<ul style="list-style-type: none"> <li>The FGRIO-M can operate as a Master in a 900 MHz I/O network.</li> <li>The FGRIO-M must have firmware 2.54 or higher installed to support wire replacement applications.</li> </ul>	x	N/A
I/O Expansion			
IOE-4440 IOE-4422 IOE-4404	<ul style="list-style-type: none"> <li>Serial bases that provides expandable, wired I/O.</li> </ul> <p><b>Note:</b> For information about the expansion models, see the LUM0017AB IO Expansion User Manual.</p> <hr/> <p><b>Important!:</b> This document does NOT provide information about the serial bases or expansion models.</p>	N/A	x
IOEX-4440 IOEX-4422 IOEX-4404	<ul style="list-style-type: none"> <li>Expansion models that can be added to a radio base or serial base device to expand the number of I/O channels available.</li> </ul>	N/A	x

Model	Description	Wire Replacement I/O	Modbus I/O
	<ul style="list-style-type: none"> <li>Expansion Modules on their own do NOT communicate.</li> <li>They must be connected to a Radio Base or a Serial Base.</li> <li>Different isolated channels are available depending on the model number.</li> </ul> <div style="border: 1px solid black; background-color: #ffffcc; padding: 5px; margin: 10px 0;"> <p><b>Note:</b> For information about the expansion models, see the LUM0017AB IO Expansion User Manual.</p> </div> <hr/> <p><b>Important!:</b> This document does NOT provide information about the serial bases or expansion models.</p>		

## 1.2 Modbus I/O Systems

Modbus is a communication protocol that you can use to send information between intelligent devices. In a FreeWave network, the device requesting information is called the serial Master and the devices supplying information are Modbus I/O Slaves.

A Modbus I/O system provides an alternative to running wires and takes advantage of Modbus Polling capabilities to monitor, configure, and control a device.

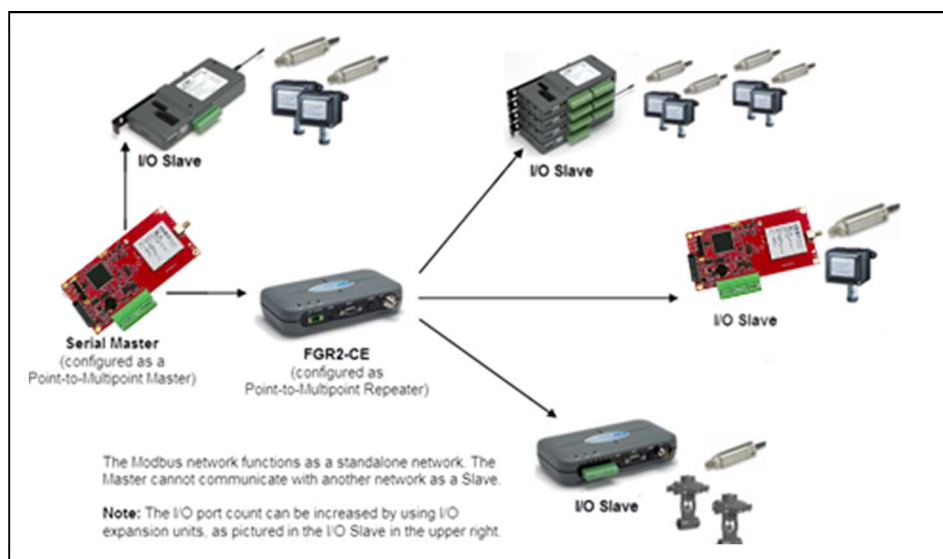

Figure 1: Example: Modbus System

## 1.3 Configuration Tool Options

**Note:** The terms **modem** and **radio** are used interchangeably in this document and in the text within the setup tools.

While the words have different meanings, the two terms should be treated as the same when referring to FreeWave products.

When the radio is in **Setup** mode, use these setup tools to configure the settings on the radio:

- **Tool Suite** - **Tool Suite** is the current configuration software and replaces EZConfig, and is the recommended method for programming your radios.
  - It provides a group of tools for configuring the devices in the network and for monitoring the network's performance. Using the **Configuration** application in **Tool Suite**, you can program changes to the radio's settings.
  - **Tool Suite** is available for download from [www.freewave.com](http://www.freewave.com).
- **Terminal Emulator** - A terminal emulator program (e.g., **TeraTerm**) offers many of the same configuration options that are available in the Configuration application in **Tool Suite**.
  - Use a chosen terminal emulator program to program the radio.
  - The **Setup Terminal** application in **Tool Suite** provides the same interface that is available using a terminal emulator.

## 1.4 Tool Suite and Terminal Emulators

If using a terminal emulator, the tabs for a device in **Tool Suite** mirror the **Setup** main menu selections.

**Example:** Option **0** from the Setup main menu in the terminal menu setup is **Set Operation Mode**. The corresponding configuration tab for the device in **Tool Suite** is **(0) Operation Mode**.

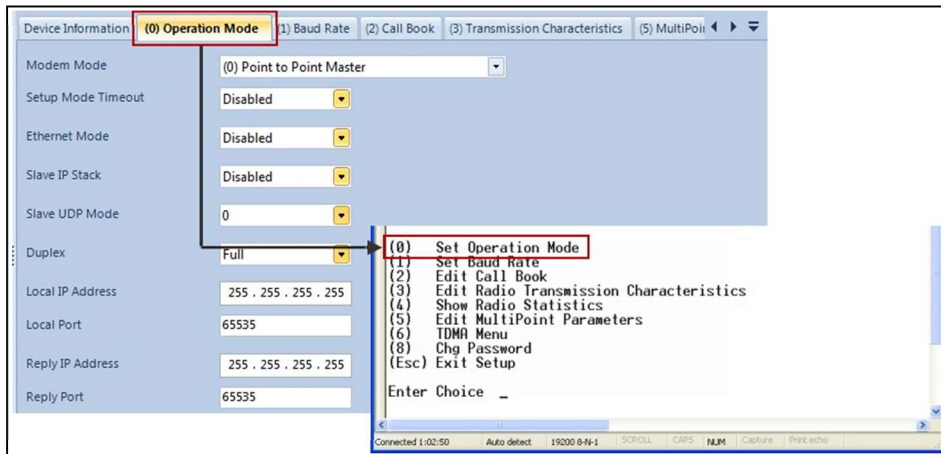

Figure 2: Example of the same options in Tool Suite and Terminal Emulator



**Tip:** Use the **Setup Terminal** application in **Tool Suite** to use and view the terminal menus. It appears with the same menus and programming settings when using a terminal emulator.

**Note:** Throughout this document, if the setup procedure in the terminal emulator is different than the procedure in **Tool Suite**, the terminal instructions are also included.

## 1.5 Radio Setup Mode

To read the current settings from or to program a radio, the radio must be in Setup mode. When a radio is in Setup mode, all three LEDs appear as solid green (●●●).

**Note:** OEM boards may also enter Setup when Pin 2 on a 10-point connector or Pin 8 on a 24-pin connector is grounded, or using a break command. For more information about the break command, see [Use Break to Access Setup \(on page 37\)](#).

The **Setup Port** parameter in the **Baud Rate** tab determines whether the main data port or the diagnostics port is used to access the setup parameters for the radio. For more information, see [Setup Port \(on page 35\)](#).

Use the **Setup Mode Timeout** parameter on the **Operation Mode** tab to set the radio to exit Setup Mode automatically. When the setting is enabled, if the radio has not received any menu selections or programming information within 5 seconds, it exits Setup and resumes its previous mode.

### 1.5.1 Using Tool Suite to Connect to and Program Radios

To read and program a radio using **Tool Suite**, to connect the radio to a computer that runs the **Tool Suite** software.



**Tip:** Use **Tool Suite** to set up a template version of a radio. Templates include settings that apply to more than one radio in the network.

## Procedure

1. Connect a serial or diagnostic cable between the computer or laptop and the radio.

**FreeWave Recommends:** Use a diagnostic cable and the diagnostic port.

2. Connect the power supply to the radio and the power source and turn on the radio.
3. With the radio connected to the computer in **Tool Suite**, click **Configuration** in the Application pane to open the Configuration application.
4. Verify the correct port is selected in the **Com Port** field in the Configuration ribbon.
5. To place enclosed radios in Setup mode, press the Setup button on the back of the FreeWave radio.

If you are connected to the diagnostics port, the radio changes to Setup mode automatically when you click **Read Radio** in **Tool Suite**.

To place board-level radios into Setup Mode:

- a. Short pins 2 & 4 (Brown to Black) on the 10 pin header next to the LEDs.
  - b. If using a data cable (FreeWave part number: ASC3610DB or ASC3610DJ), press the Setup button on the data cable.
6. Click **Read Radio** in the Configuration ribbon to read the radio's current settings.
  7. Make the necessary parameter changes and do one of the following to send the changes to the radio:
    - a. To send only the changed parameters, on the Configuration application in the Network Title ribbon, click **Quick**.

This option is only available if you clicked Read Radio and are not sending parameter settings from a template to the radio.
    - b. To send all the settings for all parameters, within the Configuration application in the Network Title ribbon, click All.
    - c. To set a device back to its factory default settings, within the Configuration application in the Network Title ribbon, click Default.

### 1.5.2 Accessing the Setup Menu Using a Terminal Emulator

Use a terminal emulator of your choice to access the **Setup** menu. For any terminal emulator application, plug the serial cable into a com port on the radio, open a session, and ensure that the port settings are set to the following for a proper connection to the radio:



Port Setting	Select
Bits per second	19200
Data Bits	8
Parity	None
Stop Bits	1
Flow Control	None

These access the radio's **Setup** menu using the Setup Terminal application in **Tool Suite**. Setup Terminal contains the port settings above, by default.

**Note:** For more information about using **Tool Suite**, see the **Tool Suite User Manual** available by selecting **File > Help** in the **Tool Suite** software.

### Procedure

8. Plug a serial cable into the Com 1 of the radio.
9. Connect the cable to a Com port on the computer running **Tool Suite**.
10. Connect the radio to a power source.
11. Open **Tool Suite**.
12. On the **Applications** pane, select **Setup Terminal**.
13. Click the **Connection** list box arrow and select the COM port on the computer the radio is connected to.

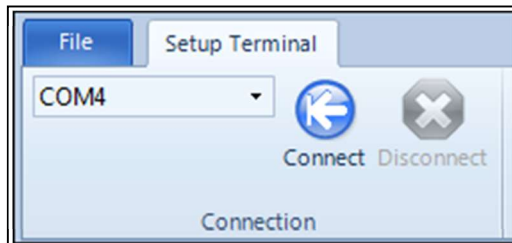

**Figure 3: Tool Suite Connection list box**

14. Click **Connect**.
15. To connect the to the radio, in enclosed radios, press the **Setup** button on the back of the FreeWave radio.
16. If connected to the diagnostics port, press <Shift+U> (Capital 'U') to activate the **Setup** menu.

## View the Setup menu in Board-level Radios

1. Short pins 2 & 4 (Brown to Black) on the 10 pin header next to the LEDs.
2. If using a data cable (Part Number: ASC3610DB or ASC3610DJ), press the Setup button.
3. If using the gray ribbon diagnostic cable (Part Number: AC2009DC) or the black diagnostic cable (Part Number: ASC0409DC), press <Shift+U> (capital U) to activate the Setup menu.

When Setup is activated, the FreeWave Setup Main Menu appears in the terminal emulator window.

- All three LEDs on the radio light green (■ ■ ■) and stay green as long as the radio is in Setup mode.
- The main setup menu appears:

```
                                MAIN MENU
                                D3 IO Version 11.0.13 02-19-2024
                                902 - 928 MHz
                                Modem Serial Number 714-8326
                                Model Code DV3C-IOS
(0)  Set Operation Mode
(1)  Set Baud Rate
(2)  Edit Call Book
(3)  Edit Radio Transmission Characteristics
(4)  Show Radio Statistics
(5)  Edit MultiPoint Parameters
(6)  TDMA Menu
(8)  Chg Password
(9)  FGRIIO Setup
(Esc) Exit Setup

Enter Choice
```

**Figure 4: Example: Tool Suite IO Main Menu**















































---



**Important!:** When navigating through the **Setup** menu and making changes to the parameters, the parameters are sent to the radio **immediately**.

---

**Note:** See [Troubleshooting Terminal Emulators \(on page 141\)](#) for more information.

## 1.6 LED Indications

Condition	Serial Master			Modbus I/O Slave			Repeater (If applicable)		
	Carrier Detect (CD)	Transmit (Tx)	Clear to Send (CTS)	Carrier Detect (CD)	Transmit (Tx)	Clear to Send (CTS)	Carrier Detect (CD)	Transmit (Tx)	Clear to Send (CTS)
Powered, not linked	Solid red bright 	Solid red dim 	Off 	Solid red bright 	Off 	Blinking red 	Solid red bright 	Off 	Blinking red 
Repeater and Slave linked to Master, no data	Solid red bright 	Solid red dim 	Off 	Solid green 	Off 	Solid red bright 	Solid green 	Solid red dim 	Solid red bright 
Repeater and Slave linked to Master, Master sending data to Slave	Solid red bright 	Solid red dim 	Off 	Solid green 	Off 	Solid red bright 	Solid green 	Solid red dim 	Solid red bright 
Repeater and Slave linked to Master, Slave sending data to Master	Solid green RCV data  or Solid red bright 	Solid red dim 	Intermittent flash red 	Solid green 	Intermittent flash red 	Solid red bright 	Solid green 	Solid red bright 	Solid red bright 
Master with diagnostics program running	Solid red bright 	Solid red dim 	Intermittent flash red 	Solid green 	Intermittent flash red 	Solid red bright 	Solid green 	Solid red bright 	Solid red bright 

\* in an idle condition, the CTS LED is solid red  with a solid link, as the link weakens the CTS LED on the Repeater and Slave begins to blink .



---

## 2. Configuring a Serial Master

This section provides information about configuring a serial Master.

1. Complete the [Using Tool Suite to Connect to and Program Radios \(on page 22\)](#) procedure.
2. Set the serial Master's role in the network on the **Operation Mode** tab.
3. Set the serial Master's data port settings in the **Baud Rate** tab to match the device that is connected to the data port.
4. Establish communication with the Modbus I/O Slaves using the **Network ID** in the **MultiPoint Parameters** tab.
5. Set the data transmission settings in the **Transmission Characteristics** tab to determine how data is sent between the serial Master and the Modbus I/O Slaves.
6. Set additional parameters that may apply to the network in the **MultiPoint Parameters** tab.

A serial Master is a serial FreeWave radio that can be set as a Multipoint Master in a network, including:

- FGR3-C
- FGR3-CE
- FGR2-C
- FGR2-CE
- FGR09CSU (board level)

The settings discussed in this section are those required for Modbus I/O and to establish a connection with the Modbus serial RTU I/O Slaves in the network system.

Other radio settings are available on the Master. For information about the other Master settings, see these User Manuals:

## 2. Configuring a Serial Master

- FGR models - FGR Wireless Data Radios User Manual and Reference Guide
- FGR2 models - FGR2 Wireless Data Radios User Manual and Reference Guide
- FGR3 models - FGR3 Wireless Data Radios User Manual and Reference Guide

### 2.1 Configuring a Serial Master

This section describes how to quickly get the serial Master in a Modbus I/O network setup and communicating with the Modbus I/O Slaves.

---

**Important!:** This procedure covers only the settings required for radio communication to and from the Master and the Modbus I/O Slaves.

---

#### Procedure

1. Connect the radio to the serial port of a computer either through a serial cable or using the diagnostics cable.
2. Connect the radio to a power source (+7.0 to +30.0 VDC).
3. Open **Tool Suite**.
4. Click **Configuration** in the Application pane.
5. Click **Read Radio** to read the radio's current settings.
6. Click the **Operation Mode** tab and select **(2) Point-to-MultiPoint Master** in the **Modem Mode** field.

**Note:** The Ethernet options that appear in this tab do not apply to a serial Master and should be left at their factory default settings.

7. Click the **Baud Rate** tab and set these parameters to match the polling host:
  - Baud Rate
  - Data Parity
  - Serial Interface
  - Flow Control
  - Modbus RTU - Must be set to 1
  - Turn On Delay - Set to 0
  - Turn Off Delay - Set to 4 if using RS485
  - Setup Port - Set to Diagnostics Only if using RS422 or RS485
8. Click the **Transmission Characteristic** tab and set these parameters:
  - Frequency Key - Set as necessary for the network
  - Max Packet Size - Set to **2** or higher
  - Min Packet Size - Set to **2** or higher
  - RF Data Rate - Set as necessary for the network
9. Click the **MultiPoint Parameters** tab and set these parameters:

- Master Packet Repeat - FreeWave recommends a setting of **2** or higher
  - Retry Time Out - Set to **0**
  - Network ID - Any number between 0 and 4095, excluding 255
  - Subnet IDs - Set to **0**
10. Send the settings to the radio using the Program All or Quick options in the Network Title ribbon in **Tool Suite**.

## 2.2 Setting the Serial Master's Role in the Network

The first parameter to set in the serial Master in a Modbus I/O system is to select its Modem Mode (or Operation Mode). The mode tells the radio what network type it is in and what role it plays and enables other settings for that radio.

Set the modem mode to **(2) Point-to-MultiPoint Master** in the **Operation Mode** tab, using the **Modem Mode** field. This setting is available in the **Operation Mode** menu in the terminal interface.

---

**Important!:** The modem mode is the only setting that is required in the **Operation Mode** tab. The Ethernet settings available are not used in a Modbus I/O network and should be left at the factory default.

---

## 2.3 Establishing Communication Between the Serial Master's Data Port and an End Device

The settings in the **Baud Rate** tab are the communication settings between the radio and the instrument or computer to which the radio's data port is connected. These settings are unique to each radio, and do not need to match across the network.

### 2.3.1 Baud Rate

Baud Rate	
Setting	Description
Default Setting:	115200
Options:	600, 1200, 2400, 4800, 9600, 19200, 38400, 57600, 76800, 115200, 230400
Terminal Menu:	(1) Set Baud Rate
Description:	<p>This is the communication rate between the radio's data port and the instrument to which it is connected.</p> <ul style="list-style-type: none"> <li>• This setting is independent from the Baud Rate for the other radios in the network.</li> </ul>

## 2. Configuring a Serial Master

Option	Data Bits	Parity	Stop Bits
0	8	None	1
1	7	Even	1
2	7	Odd	1
3	8	None	2
4	8	Even	1
5	8	Odd	1

Baud Rate	
Setting	Description
	<ul style="list-style-type: none"> <li>Set the baud rate to the highest level supported by the device to which it is connected.</li> <li>With a poor radio link, however, this may result in slower data communications.</li> </ul> <hr/> <p><b>FreeWave Recommends:</b> With a <b>Baud Rate</b> setting of 38,400 or higher, use the Flow Control lines.</p> <hr/> <p><b>Note:</b> The Setup port baud rate always defaults to 19,200 no matter how the data port baud rate is set.</p>

### 2.3.2 Data Parity

Data Parity	
Setting	Description
Default Setting:	0 (8, N, 1)
Options:	See table below.
Terminal Menu:	(1) Set Baud Rate > (A) Data Parity



<p>Description:</p>	<p>Six data word length and parity configurations are available for use with FreeWave radios.</p> <p>The default setting is <b>8-None-1</b> and is the most commonly used serial communications protocol.</p>
---------------------	---

## 2. Configuring a Serial Master

### 2.3.3 Flow Control

Flow Control	
Setting	Description
Default Setting:	(0) None
Options:	<ul style="list-style-type: none"> <li>• (0) None - No flow control CTS is active and de-asserts when buffering is 98% full. Can pass XON/XOFF data but does not use it in any way.</li> <li>• (1) RTS - Uses standard RTS/CTS control lines</li> <li>• (2) DTR</li> </ul>
Terminal Menu:	(2) Set Baud Rate > (F) FlowControl
Description:	<p>Specifies the hardware flow control for the data port on the radio.</p> <p><b>FreeWave Recommends:</b> Use <b>Flow Control</b> if the Baud Rate is higher than 19200.</p>

### 2.3.4 Modbus RTU

**Note:** When using the radio in **Modbus RTU** mode, the **Master Packet Repeat** setting in the MultiPoint Parameters tab must match in every radio. The **Modbus RTU** mode must be set to **1** when radios are configured in RS485 or RS422 mode.

Modbus RTU	
Setting	Description
Default Setting:	0 (Disabled)
Options:	1
Terminal Menu:	(1) Set Baud Rate > (B) <b>Modbus RTU</b>
Description:	<p>In a Modbus I/O system, this setting must be set to 1.</p> <p>The radio waits for a number of slots equal to two times the <b>Master Packet Repeat</b> setting before sending the received data out the radio link. For example, if the <b>Master Packet Repeat</b> parameter is set to <b>3</b>, the radio waits for <b>6</b> slots, gathering data up the whole time. At the end of the <b>6</b> slots, the radio sends all received data in one “burst.” This is the appropriate setting for most <b>Modbus RTU</b> devices.</p>

## 2.3.5 Serial Interface

Serial Interface	
Setting	Description
Default Setting:	(0) RS232
Options:	<ul style="list-style-type: none"> <li>• (0) RS232 - Also used for TTL.</li> <li>• (1) RS422 - <ul style="list-style-type: none"> <li>• <b>Modbus RTU</b> must be enabled</li> <li>• <b>Turn Off Delay</b> set to at least 4.</li> </ul> </li> <li>• (2) RS485 - <ul style="list-style-type: none"> <li>• <b>Modbus RTU</b> must be enabled</li> <li>• <b>Turn Off Delay</b> set to at least 4.</li> </ul> </li> <li>• (3) DOT - <ul style="list-style-type: none"> <li>• DOT causes the CD line to indicate when data is transmitted on the serial port from the radio.</li> <li>• When the radio is not sending data to the serial port, CD is de-asserted.</li> <li>• When the radio is sending data to the serial port, CD is asserted.</li> <li>• The CD line no longer has any radio link state functionality.</li> <li>• <b>Turn Off Delay</b> works as described in all radios.</li> <li>• <b>Turn On Delay</b> works as described on any Slave or Slave/Repeater - it has no functionality on the Master.</li> </ul> </li> </ul> <p><b>Note:</b> If set to anything other than 0, the <b>Setup Port</b> parameter on the <b>Baud Rate</b> tab must be set to <b>Diagnostics Only</b>.</p>
Terminal Menu:	(1) Set Baud Rate > (C) RS232/485
Description:	Use this option to set the protocol of the data port.

## 2.3.6 Setup Port

**Important!:** Do NOT change this setting unless the correct programming cable is available for the new setting.

Setup Port	
Setting	Description
Default Setting:	(3) Both
Options:	<ul style="list-style-type: none"> <li>• (1) Main Only - Programming and reading a radio's setup information is done through the data port.</li> </ul>

## 2. Configuring a Serial Master

Setup Port	
Setting	Description
	<ul style="list-style-type: none"> <li>• (2) Diagnostics Only - Programming and reading a radio's setup information is done through the diagnostic port.</li> <li>• If the <b>Serial interface</b> is set to anything other than RS232, then the <b>Setup Port</b> must be set to <b>Diagnostics Only</b>.</li> <li>• (3) Both - Programming and reading a radio's setup information is done through either the data port or the diagnostic port.</li> </ul>
Terminal Menu:	(1) Set Baud Rate > (D) Setup Port
Description:	Determines which port on the radio, Main or Diagnostics, is used to access the parameter settings in <b>Tool Suite</b> or enter the Setup main menu in the terminal interface.

### 2.3.7 Turn Off Delay

Turn Off Delay	
Setting	Description
Default Setting:	0
Options:	Any number between 0 and 9.
Terminal Menu:	(1) Edit Baud Rate > Turn Off Delay
Description:	<ul style="list-style-type: none"> <li>• Specifies the time after the end of transmission of a character to the RS485 bus that the radio stops driving the bus and releases the bus to other devices.</li> <li>• The units are ¼ of a character with a range from 0 to 9.</li> <li>• An entry of <b>4</b> means a delay equivalent to the duration of a full character.</li> <li>• <b>Turn Off Delay</b> must be set to a value of at least <b>4</b> for RS422 and RS485 operation.</li> <li>• The default is zero delay.</li> <li>• For data rates of 1200 bits/S or slower, avoid setting the <b>Turn Off Delay</b> parameter higher than <b>4</b>.</li> <li>• At those rates the functionality of the microprocessor changes so that a <b>Turn Off Delay</b> of <b>5</b> has the same effect as if set to <b>1</b>, and a setting of <b>6</b> has the same effect as <b>2</b>, and so on.</li> </ul>

### 2.3.8 Turn On Delay

Turn On Delay	
Setting	Description
Default Setting:	0 ms
Options:	Any number between 1 and 9 ms.
Terminal Menu:	(1) Set Baud Rate > (E) Turn On Delay
Description:	Sets the delay between when the line drivers are turned on and when the data leaves the data port.

### 2.3.9 Use Break to Access Setup

**Note:** This setting is typically only used in OEM scenarios.

Use Break to Access Setup	
Setting	Description
Default Setting:	Disabled
Options:	<ul style="list-style-type: none"> <li>• (0) - Disabled - The break command is disabled in the radio.</li> <li>• (1) - Enabled - The Setup menu is set at 19200 bps.</li> <li>• (2) - Enabled - The Setup menu is set at the radio's current baud rate.</li> <li>• This setting is only available through the terminal interface.</li> </ul>
Terminal Menu:	(2) Set Baud Rate > (G) Use break to access setup
Description:	<ul style="list-style-type: none"> <li>• Enables a break command to put the radio into Setup mode over the data port.</li> <li>• To send a break character the end device must hold the Tx data line in the space voltage level for longer than 1 character time.</li> </ul> <p><b>Example:</b> If a character is defined as having 1 start bit, 8 data bits, and 1 stop bit, the character time is 10 bits, thus the Tx data line must be held in the space voltage level for a period of time longer than 10 bits.</p>

## 2.4 Establishing Communication with Modbus I/O Slaves

For the serial Master to communicate with the Modbus I/O Slaves, use the **Network ID** setting to instruct the serial Master what other devices it can communicate with.

---

**Important!:** The **Call Book** is NOT used in a Modbus I/O system.

---

In the serial Master's MultiPoint Parameters tab, enter an ID in the **Network ID** field that meets these guidelines. Radios from the factory have a default ID of 255.

## 2. Configuring a Serial Master

- The value can be any value between 0 and 4095, except 255.
- Avoid using numbers that coincide with nearby landmarks or highways.

**FreeWave Recommends:** Use an ID of four characters.

**Example:** The last four digits of the I/O Master's serial number, which is ensured to be unique and does not overlap with other nearby FreeWave networks.

**Important!:** If the I/O Master's **Modem Mode** is set to **(3) Point to MultiPoint Slave**, its **Network ID** MUST match the network's Master.

## 2.5 Setting Serial Master RF Transmission Characteristics

The Transmission Characteristics parameters are used to change settings that determine how data is sent between radios in the network. Many of these parameters must be maintained throughout the network for proper functionality.

In a serial Master, set these parameters in the **Transmission Characteristics** tab.

**Note:** These parameters are also available in the **Edit Radio Transmission Characteristics** menu in the terminal interface.

- Frequency Key
- Max Packet Size
- Min Packet Size
- RF Data Rate

The remaining parameters in the Transmission Characteristics tab can remain at their factory default settings to establish a link with the Modbus I/O Slaves.

### 2.5.1 Frequency Key

Frequency Key	
Setting	Description
Default Setting:	5
Options:	0 to 9 and A to E  <b>FreeWave Recommends:</b> Change the <b>Frequency Key</b> setting to an option other than 5.
Terminal Menu:	(3) Edit Radio Transmission Characteristics > (0) FreqKey
Description:	<ul style="list-style-type: none"><li>• Fifteen choices are available for the <b>Frequency Key</b> (0-9 and A-E) setting, representing 15 different pseudo-random hop patterns.</li></ul>

Frequency Key	
Setting	Description
	<ul style="list-style-type: none"> <li>Hopping patterns minimize the interference with other FreeWave radios operating in the area.</li> <li>Use the <b>Hop Table Version</b>, <b>Hop Table Size</b>, and <b>Frequency Zone</b> fields to define more network differentiation by way of limiting the number and location of frequencies the radios may hop on in the 902-928MHz band.</li> </ul> <div style="background-color: #e0e0e0; padding: 10px; margin: 10px 0;"> <p><b>Example:</b> If 10 pairs of FreeWave radios are operating on different networks in close proximity, setting a different <b>Frequency Key</b> value reduces the chance that radios hop to the same frequency at the same time. If two networks were to hop to the same frequency, the next hop would be to a different frequency for both networks.</p> </div> <div style="border: 1px solid #00a0e3; padding: 10px; margin: 10px 0;">  <b>Tip:</b> Gain additional network separation by adjusting the <b>Max Packet Size</b> and <b>Minimum Packet Size</b>.                 </div>

## 2.5.2 Max Packet Size and Min Packet Size

Max Packet Size and Min Packet Size	
Setting	Description
Default Options:	Max Packet Size = 8 Min Packet Size = 9
Options:	<ul style="list-style-type: none"> <li>Any number between 0 and 9.</li> </ul> <p><b>FreeWave Recommends:</b> In a Modbus I/O system, set both the <b>Maximum Packet Size</b> and <b>Minimum Packet Size</b> to <b>2</b> or higher.</p>
Terminal Menu:	(3) Edit Transmission Characteristics > (1) Max Packet Size and (2) Min Packet Size
Description:	<p>Set to match the Modbus I/O Slave, using the following guidelines:</p> <ul style="list-style-type: none"> <li>Modbus I/O Systems using packet sizes of <b>2</b> and <b>2</b> typically draw more current than if the systems were programmed to use larger packet sizes.</li> <li>There is a relationship between packet size and maximum reliable counting rate of the DI Counters.</li> <li>With <b>Max Packet Size</b> set to <b>2</b>, <b>Min Packet Size</b> set to <b>2</b>, a maximum of 1000Hz (at 50% duty cycle, 500 µs per phase) can be counted.</li> </ul>

## 2. Configuring a Serial Master

Max Packet Size and Min Packet Size	
Setting	Description
	<ul style="list-style-type: none"> <li>The Modbus I/O system functions with larger packet sizes, but the count rate is reduced.</li> <li><b>Max Packet Size</b> set to <b>9</b>, <b>Min Packet Size</b> set to <b>9</b> reliably counts to 10Hz (50 msec per phase).</li> </ul>

## 2.6 Setting Serial Master MultiPoint Parameters

The MultiPoint Parameter options are used to change several different parameters in the radio that determine the characteristics of a MultiPoint network.

In a serial Master in a Modbus I/O system, these parameters must be set in the **MultiPoint Parameters** tab.

**Note:** These settings are available in the **MultiPoint Parameters** menu in the terminal interface.

- Master Packet Repeat
- Repeaters
- Network ID - See [Establishing Communication with Modbus I/O Slaves \(on page 37\)](#).

### 2.6.1 Master Packet Repeat

Master Packet Repeat	
Setting	Description
Default Setting:	3
Options:	Any number between <b>0</b> and <b>9</b> .
Terminal Menu:	(5) Edit MultiPoint Parameters > (1) Master Packet Repeat
Description	<p>In a Point-to-MultiPoint network, Slave radios do not acknowledge transmissions from the Master.</p> <ul style="list-style-type: none"> <li>If Slave radios did acknowledge all data transmissions, in a large network, the Master would soon become overwhelmed with acknowledgments from the Slaves.</li> <li>Without acknowledgments, 100% confidence every Slave radio has received every packet cannot be met.</li> <li>To address this issue, change the <b>Master Packet Repeat</b> parameter, assigning a value between <b>0</b> (the packet is transmitted once) to <b>9</b> (the packet is transmitted 10 times).</li> </ul> <p>For networks with solid RF links, this parameter should be set to a low value (e.g., <b>1</b> or <b>2</b>).</p> <ul style="list-style-type: none"> <li>If a network has some weak or marginal links it should be set with</li> </ul>



	<p>higher values.</p> <ul style="list-style-type: none"><li>• If a Slave radio receives a good packet from a Master more than once it discards the repeated packets.</li><li>• Similarly, after a MultiPoint Repeater receives a good packet from the Master, it discards any further repeated packets.</li><li>• In turn, the Repeater sends the packet out to the next Repeater or Slaves the number of times corresponding to its own <b>Master Packet Repeat</b> setting.</li></ul> <p>Increasing the <b>Master Packet Repeat</b> setting increases the probability of a packet getting through, but also increases latency in the network because each packet from the Master or Repeater is being sent multiple times.</p> <p><b>Note:</b> Therefore, it is important to find the optimal mix between network robustness, throughput, and latency. In general, a setting of <b>2</b> to <b>3</b> works well for most well-designed networks.</p> <p>The <b>Master Packet Repeat</b> parameter may be set to <b>0</b> if the user software is capable of, or requires acknowledgment.</p> <p>In this case, if the Master sends a packet that the Slave radio does not receive, the user software controls the retries as needed.</p>
--	---

### 2.6.2 Repeaters

Repeaters	
Setting	Description
Default Setting	Enabled
Options:	(0) Disabled, (1) Enabled
Terminal Menu:	(5) MultiPoint Parameters > (0) Number Repeaters
Setting:	<ul style="list-style-type: none"> <li>Set to <b>Enabled</b> if any number of Repeaters exist in the network.</li> <li>Set to <b>Disabled</b> if the network contains no Repeaters.</li> </ul>

### 2.6.3 Subnet ID - Serial Master

Subnet ID	
Setting	Description
Default Setting:	F, F
Options:	<ul style="list-style-type: none"> <li>Any number between 0 and 9</li> <li>Any letter between A and F</li> </ul>
Terminal Menu:	(5) Edit MultiPoint Parameters > (C) Subnet ID
Description	<ul style="list-style-type: none"> <li>The Subnet ID setting only applies in an I/O Master when its Modem Mode is set to <b>(3) Point to MultiPoint Slave</b>.</li> <li>If the I/O Master is in a standalone system with a <b>Modem Mode</b> setting of <b>(3) FGRIO Master</b>, both the Rx and Tx components of the Subnet ID should be set to F.</li> </ul> <p>Two components exist with regard to the Subnet ID:</p> <ul style="list-style-type: none"> <li>Rx - This setting identifies which radio the serial Master listens to.                             <ul style="list-style-type: none"> <li>In a serial Master, set the <b>Rx</b> component to <b>0</b>.</li> <li>In the terminal menu, this is the <b>Rcv Subnet ID</b>.</li> </ul> </li> <li>Tx - This setting identifies the ID this device transmits on and which devices listen to it.                             <ul style="list-style-type: none"> <li>In a serial I/O Master, set the <b>Tx</b> component to <b>0</b>.</li> <li>In the terminal interface, this is the <b>Tx Subnet ID</b>.</li> </ul> </li> </ul>

---

## 3. Configuring a Modbus I/O Slave

This section provides information about:

- The configuration of a Modbus I/O Slave in a Modbus I/O system.
- The settings required for Modbus I/O and to establish a connection with the serial Master Modbus I/O system.
- Other radio settings available on the Modbus I/O Slaves.
  - For more information, see [Other Radio Settings \(on page 60\)](#).
- The Modbus I/O Slave register map and register descriptions beginning [Modbus I/O Slave Register Map \(on page 99\)](#).

### Procedure

1. Follow the [Using Tool Suite to Connect to and Program Radios \(on page 22\)](#) procedure to connect to and read the settings from a Modbus I/O Slave in **Tool Suite**.
2. Set the Modbus I/O Slave's role in the network in the **Operation Mode** tab.
3. Establish communication the Master using the Network ID in the **MultiPoint parameters** tab.
4. Set the data transmission settings in the **Transmission Characteristics** tab to determine how data is sent to the Master.
5. Set additional parameters that apply to a Modbus I/O system in the **MultiPoint Parameters** tab.
6. Set the Modbus I/O Slave-specific settings in the **Modbus Settings** tab.

## 3.1 Configuring a Modbus I/O Slave

Use this procedure to set up an I/O Slave in a Modbus I/O network.

**Note:** Parameter settings not included in the procedure can be set at later or remain at the factory default setting.

### Procedure

1. Connect the radio to the serial port of a computer either through a serial cable or using the diagnostics cable.
2. Connect the radio to a power source (+7.0 to +30.0 VDC).
3. Open **Tool Suite**.
4. Click **Configuration** in the Application pane.
5. Click **Read Radio** to read the radio's current settings.
6. Click the **Operation Mode** tab and select **(3) Point-to-MultiPoint Slave** in the **Modem Mode** field.
7. Click the **Baud Rate** tab and set these parameters to match the polling host:
  - Baud Rate
  - Data Parity
  - Serial Interface
  - Flow Control
  - Modbus RTU - Must be set to 1
  - Turn On Delay - Set to 0
  - Turn Off Delay - Set to 4 if using RS485
  - Setup Port - Set to Diagnostics Only if using RS422 or RS485
8. Click the **Transmission Characteristic** tab and set these parameters to the same settings as the I/O Master:
  - Frequency Key
  - Max Packet Size
  - Min Packet Size
  - Hop Table Version
  - Hop Table Size
9. Click the **MultiPoint Parameters** tab and set these parameters to match the serial Master:
  - Master Packet Repeat - Set to 3
  - Retry Odds - Set to **0**
  - Network ID - Set to match the Master

- Subnet Rx - Set to **0**
  - Subnet Tx - Set to **F**
10. Click the **Modbus Settings** tab and set these parameters:
- Modbus Mode - Set to **Enabled** so the Modbus I/O Slave can respond to Modbus polls.
  - Modbus Address Size - Select the addressing option.
    - 16 bit addressing requires Firmware v2.65 or higher.
  - Modbus ID - Select a value from:
    - 1 to 246 in 8 bit addressing.
    - 1 to 65535 in 16 bit addressing.
  - Sensor Power Default - Select the default output of the sensor power pin at power-on.
  - AI1 User Offset and AI2 User Offset - Subtracts from the AI1 and AI2 MSW (Most Significant Word) measurements to provide zero-shifted versions of AI1 and AI2.
  - DI1 Pullup and DI2 Pullup - Sets the power-up state of the internal resistor (10 KOhms) connected to the Digital Inputs.

---

**Important!** When toggling this coil between **ON** and **OFF**, the device automatically reboots.

---

- DI 1 Counter Edge and DI 2 Counter Edge
  - Clear Cntr 1 on Read and Clear Cntr 2 on Read
  - Digital Out 1 Default and Digital Out 2 Default - Controls the state of the digital output defaults invoked on loss of communication.
  - Default Delay - Enter the amount of time that the I/O Slave waits before entering the default state defined in Digital Out 1 Default and Digital Out 2 Default. A setting of:
    - 1 = 1/6 second
    - 6 = 1 second
    - 42 = 7 seconds
    - 252 = 42 seconds
11. Send the settings to the radio using the **Program All** or **Quick** options in the **Network Title** ribbon in **Tool Suite**.

## 3.2 Modbus I/O Slaves in Tool Suite

When reading an I/O Slave's settings through **Tool Suite**, the radio displays as an FGR3 900MHz I/O Slave, FGR3 MHz I/O Slave (enclosed), FGR 900 MHz I/O Slave, FGR2 900 MHz I/O Slave, or FGR2 900 MHz I/O Slave (Enclosed).

When creating a radio template for an I/O Slave in the Configuration application in **Tool Suite**, select these radio types to ensure that the proper settings appear:

- FGR3 900 MHz I/O Slave - For the FGR3-IO-S-C-U (board level) and the FGR3-IO-IOE models.
- FGR 900 MHz I/O Slave - For the FGRIO-S model.
- FGR2 900 MHz I/O Slave - For the FGR2-IO-S-C-U (board-level) and the FGR2-IO-IOE models.
- FGR2 900 MHz I/O Slave (Enclosed) - For the FGR2-IO-S-CE-U model.
- This options exposes additional settings in the Wire Replacement tab for the internal resistors available only in this model.

**Note:** For more information about using **Tool Suite**, see the **Tool Suite User Manual** available by selecting **File > Help** in the **Tool Suite** software.

## 3.3 Setting the Modbus I/O Slave's Role in the Network

The first parameter to set in a Modbus I/O Slave in a Modbus I/O system is to select its Operation Mode or Modem Mode. The mode tells the radio what network type it is in and what role it plays.

The selected mode enables other settings for that radio.

Set the **Modem Mode** in the **Operation Mode** tab, using the **Modem Mode** field.

**Note:** These settings are available in the **Operation Mode** menu in the terminal interface.

In a Modbus I/O system, assign each Modbus I/O Slave the **(3) Point to MultiPoint Slave** operation mode. Selecting this option enables the Modbus I/O options in the Modbus Settings tab.



**Caution:** Do not set the **Operation Mode** to **(E) FGRIO IO Slave (NOT IO-MODEBUS)** or to **Serial Modbus Slave**.

## 3.4 Establishing Communication Between the Modbus I/O Slave and an End Device

The settings in the **Baud Rate** tab are the communication settings between the radio and the instrument or computer to which the radio's data port is connected. These settings are unique

to each radio, and do not need to match across the network.

If a serial device is or will be connected to the Modbus I/O Slave's serial port, the radio's settings in the **Baud Rate** tab should match the baud rate of the connected device. The descriptions of the settings in the Baud Rate tab are the same for a Modbus I/O Slave as they are for a serial Master.

### 3. Configuring a Modbus I/O Slave

**Note:** For more information about each, see the descriptions in [Establishing Communication Between the Serial Master's Data Port and an End Device \(on page 29\)](#).

## 3.5 Establishing Communication with the Serial Master

For the Modbus I/O Slave to communicate with the serial Master, set the **Network ID** on the Modbus I/O Slave to the same setting as the serial Master.

---

**Important!:** The **Call Book** is NOT supported in a Modbus I/O system. A Network ID is required.

---

## 3.6 Modbus I/O Slave RF Transmission Characteristics

The Transmission Characteristics parameters are used to change settings that determine how data is sent between radios in the network. In each Modbus I/O Slave in the Modbus I/O system, set these parameters to match those set in the serial Master:

- Frequency Key
- Hop Table Version
- Hop Table Size
- Max and Min Packet Size

The remaining parameters in the **Transmission Characteristics** tab can remain at their factory default settings to establish a link with the serial Master or can be set at your discretion.

**Note:** Each of the additional parameters is described in detail in [Setting Other RF Transmission Characteristics \(on page 55\)](#).

## 3.7 Modbus I/O Slave MultiPoint Parameters

The MultiPoint Parameter options are used to change several different parameters in the radio that determine the characteristics of a MultiPoint network.

In a Modbus I/O Slave, set these parameters in the **MultiPoint Parameters** tab to match the serial Master:

- Master Packet Repeat
- Network ID
- Repeaters
- Set the **Subnet Rx** parameter to **0** (if a Repeater is not present in the network)
- Set the **Subnet Tx** parameter to **F** in each Modbus I/O Slave. If a Repeater is present, set the Subnet Rx parameter to the same value as the Repeater's **Subnet Tx** parameter.



The remaining parameters in the **MultiPoint Parameters** tab can remain at their factory default settings. Each of the additional parameters is described in detail in [Setting Other MultiPoint Parameters \(on page 71\)](#).

## 3.8 Modbus I/O Slave Modbus Parameters

The other Modbus Settings options are used to set specific parameters to identify the Modbus I/O Slave as a Modbus I/O Slave and to set the behavior of the Digital Output and Digital Inputs on the device. Set the parameters in each Modbus I/O Slave's **Modbus Settings** tab using the descriptions below.

**Note:** These settings are available in the **FGRIO Setup** menu in the terminal interface.

### 3.8.1 AI1 User Offset and AI2 User Offset

AI1 User Offset and AI2 User Offset	
Setting	Description
Default:	0
Options:	Any value.
Terminal Menu:	(9) FGRIIO Setup > (C) AI1 Custom Offset
Description:	Enter the value that is subtracted from the AI1 MSW (Most Significant Word) value or the AI2 MSW (Most Significant Word) value, respectively. The result is provided in the 30014 AI1 MSW Offset Result Register value for analog input 1 and in the 30015 AI2 MSW Offset Result Register value for analog input 2.

### 3.8.2 AI1 250 Ohms and AI2 250 Ohms

**Note:** Applies only to the FGR2-IO2-CE-U model.

AI1 250 Ohms and AI2 250 Ohms	
Setting	Description
Default Setting:	Disabled
Options:	Disabled, Enabled
Terminal Menu:	(9) FGRIIO Setup > (I) AI (DI1) Filter (9) FGRIIO Setup > (J) AI (DI2) Filter
Description:	<ul style="list-style-type: none"> <li>The FGR2-IO2-CE-U includes a switchable and protected 250 <math>\Omega</math> resistor when connecting the I/O Slave to a 4-20 mA sensor.</li> <li>When enabled, the resistor can take the place of an inline resistor between the device and the Slave's analog input.</li> </ul>

### 3.8.3 AO1 Custom Offset and AO2 Custom Offset

**Note:** This parameter is not available in the FGRIIO-S models.

AO1 Custom Offset and AO2 Custom Offset	
Setting	Description
Default:	0
Options:	Any whole number.
Terminal Menu:	(9) FGRIIO Setup
Description:	<ul style="list-style-type: none"> <li>User-entered value that is added to the AO1 Command value or AO2 Command value, respectively.</li> <li>The resulting total is the value reported when reading the AO1 Command register value or AO2 Command register value, respectively.</li> </ul>

### 3.8.4 AO1 Unchanged and AO2 Unchanged

**Note:** This parameter is not available in the FGRIIO-S models.

AO1 Unchanged and AO2 Unchanged	
Setting	Description
Default:	Enabled
Options:	<ul style="list-style-type: none"> <li>Disabled - If communication is lost, the AO1 Command or AO2 Command, respectively is set to the value in AO1 Default Cmd or AO2 Default Cmd.</li> <li>Enabled - If communication is lost, the AO1 Command or AO2 Command remains set at the last written value.</li> </ul>
Terminal Menu:	(9) FGRIIO Setup
Description:	<p>Controls the state of the analog output invoked on loss of communication.</p> <p><b>Note:</b> The <b>Default Delay</b> parameter controls the timing.</p>

### 3.8.5 AO1 Default CMD and AO2 Default CMD

**Note:** This parameter is not available in the FGRIIO-S models.

AO1 Default CMD and AO2 Default CMD	
Setting	Description
Default:	0
Options:	Any whole number.
Terminal Menu:	(9) FGRIO Setup
Description:	Upon loss of communication, if the AO1 Unchanged or AO2 Unchanged setting is set to Disabled, the AO1 Command or AO2 Command is set to this value.

### 3.8.6 Clear Counter 1 on Read and Clear Counter 2 on Read

“Clear Cntr 1 on Read” and “Clear Cntr 2 on Read”	
Setting	Description
Default:	Enabled
Options:	<p>This parameter only works when both 16 bit registers (DI1 Counter MSW and DI1 Counter LSW or DI2 Counter MSW and DI2 Counter LSW) are read together in a single Modbus poll.</p> <ul style="list-style-type: none"> <li>• Disabled - The values in DI1 Counter MSW and DI1 Counter LSW, and DI2 Counter MSW, DI2 Counter LSW, respectively are not automatically cleared. <ul style="list-style-type: none"> <li>• In the terminal interface, this is the No setting.</li> </ul> </li> <li>• Enabled - The values in DI1 Counter MSW and DI1 Counter LSW, and DI2 Counter MSW and DI2 Counter LSW, respectively, are cleared immediately after a Modbus Read command is executed. <ul style="list-style-type: none"> <li>• This can prevent loss of counts which could occur between a Read operation and a later Clear operation.</li> <li>• In the terminal interface, this is the Yes setting.</li> </ul> </li> </ul>
Terminal Menu:	(9) FGRIO Setup > (A) Clear Cntr 1 on Read (9) FGRIO Setup > (B) Clear Cntr 2 on Read

### 3.8.7 Clip AI1 Offset at Zero and Clip AI2 Offset at Zero

Clip AI1 Offset at Zero and Clip AI2 Offset at Zero	
Setting	Description
Default:	Enabled
Options:	<b>For analog input 1</b>

### 3. Configuring a Modbus I/O Slave

Clip AI1 Offset at Zero and Clip AI2 Offset at Zero	
Setting	Description
	<ul style="list-style-type: none"> <li>Disabled - If the value of AI1 User Offset is greater than the value of AI1 MSW, the value of AI1 MSW Offset Result wraps around to the top of the scale.  <div style="background-color: #e0e0e0; padding: 5px; margin: 5px 0;"> <b>Example:</b> AI1 User Offset = 10000 and AI1 MSW = 5000.                      The value of AI1 MSW Offset Result would be 60535.                 </div> </li> <li>Enabled - If the value of AI1 User Offset is greater than the value of AI1 MSW, the value of AI1 MSW Offset Result is clipped at 0 and does not wrap around to the top of the scale.  <div style="background-color: #e0e0e0; padding: 5px; margin: 5px 0;"> <b>Example:</b> AI1 User Offset = 10000 and AI1 MSW = 5000.                      The value of AI1 MSW Offset Result would be 0.                 </div> </li> </ul> <p><b>For analog input 2</b></p> <ul style="list-style-type: none"> <li>Disabled - If the value of AI2 User Offset is greater than the value of AI2 MSW, the value of AI2 MSW Offset Result wraps around to the top of the scale.  <div style="background-color: #e0e0e0; padding: 5px; margin: 5px 0;"> <b>Example:</b> AI2 User Offset = 10000 and AI2 MSW = 5000.                      The value of AI2 MSW Offset Result would be 60535.                 </div> </li> <li>Enabled - If the value of AI2 User Offset is greater than the value of AI2 MSW, the value of AI2 MSW Offset Result is clipped at 0 and does not wrap around to the top of the scale.  <div style="background-color: #e0e0e0; padding: 5px; margin: 5px 0;"> <b>Example:</b> AI2 User Offset = 10000 and AI2 MSW = 5000.                      The value of AI2 MSW Offset Result would be 0.                 </div> </li> </ul>
Terminal Menu:	(9) FGRIIO Setup > (C) AI1 Custom Offset (9) FGRIIO Setup > (D) AI2 Custom Offset
Description:	Determines the behavior of the offset result if the user offset is greater than the value of the Most Significant Word (MSW).

### 3.8.8 Counting Mode

**Note:** This parameter is not available in the FGRIIO-S models.

Counting Mode	
Setting	Description
Default:	Debounced

Counting Mode	
Setting	Description
Options:	<ul style="list-style-type: none"> <li>• Fast - The currently sampled voltage is directly compared to the previous value to determine if the Counter should be incremented.</li> <li>• Debounced - The voltage is observed over 2 – 3 consecutive samples. Only if all of the sampled values are different from the previous Counter state will the Counter increment.</li> <li>• Filtered - The currently sampled voltage is compared to an ongoing average of values. If the sampled value is different from the ongoing average, the Counter will be incremented.</li> </ul>
Terminal Menu:	(9) FGRIIO Setup

### 3.8.9 Default Delay

Default Delay	
Setting	Description
Default:	0
Options:	Any number of seconds. See below.
Terminal Menu:	(9) FGRIIO Setup > (0) Default Delay
Description:	<p>This setting configures the time the radio waits after a loss of communication with the serial Master or Repeater, before it enters the default condition.</p> <p>The value is set in 0.28 second units. For example, a value of 36 represents <math>36 \times 0.28 = 10.08</math> seconds.</p> <p>Set between 0 and 255 using these examples as guidelines:</p> <ul style="list-style-type: none"> <li>• 1 = 0.28 seconds</li> <li>• 4 = 1.12 seconds</li> <li>• 25 = 7 seconds</li> <li>• 255 = 71.4 seconds</li> </ul>

### 3.8.10 DI1 125 Ohms and DI2 125 Ohms

**Note:** Applies only to the FGR2-IOS-CE-U model.

DI1 125 Ohms and DI2 125 Ohms	
Setting	Description
Default:	Disabled

### 3. Configuring a Modbus I/O Slave

DI1 125 Ohms and DI2 125 Ohms	
Setting	Description
Options:	Disabled, Enabled
Terminal Menu:	(9) FGRIIO Setup > (I) AI (DI1) Filter (9) FGRIIO Setup > (J) AI (DI2) Filter
Description:	<ul style="list-style-type: none"> <li>The FGR2-IO2-CE-U includes a switchable and protected 125 Ω resistor for use when using 4-20 mA sensors.</li> <li>The resistor converts the 4-20 mA signal applied to the digital input into a 0.5-2.5 V signal.</li> </ul>

#### 3.8.11 DI1 Pullup and DI2 Pullup

DI1 Pullup and DI2 Pullup	
Setting	Description
Default Setting:	Pullup
Options:	<ul style="list-style-type: none"> <li>Pullup - The 10 KΩ internal resistor attached to the input is connected to the 3.3 V logic supply to provide a pull up for connecting closed-contact- to-GND sensors.</li> <li>Pulldown - The 10 KΩ internal resistor attached to the input is connected to GND to provide a pull up for connecting closed-contact-to-voltage sensors.</li> <li>Float - The internal resistor is not connected, allowing the connected sensor to provide greater than 1.75 VDC for High and less than 1.75 VDC for Low.</li> </ul>
Terminal Menu:	(9) FGRIIO Setup > (E) DI1 Pull Up/Down and (F) DI2 Pull Up/Down
Description:	<p><b>Important!</b> When toggling this coil between <b>ON</b> and <b>OFF</b>, the device automatically reboots.</p> <ul style="list-style-type: none"> <li>These parameters control the power-up states of the internal resistor (10 KΩ) connected to the Digital Inputs.</li> <li>They can pull up, such as when using a closed-contact-to-GND switch input, pull down so that unused inputs read "0" as DIs or ~0 as auxiliary analogs, or float to not load analog inputs.</li> </ul>

### 3.8.12 DI1 Counter Edge and DI2 Counter Edge

DI1 Counter Edge and DI2 Counter Edge	
Setting	Description
Default:	Falling
Options:	Falling, Rising
Terminal Menu:	(9) FGRIO Setup > (7) DI1 Counter Edge (9) FGRIO Setup > (8) DI2 Counter Edge
Description:	Determines whether the Counter for the digital input increments on the Falling edge or the Rising edge of the voltage reading.

### 3.8.13 Digital Output 1 Default and Digital Output 2 Default

Digital Output 1 Default and Digital Output 2 Default	
Setting	Description
Default Setting:	FGR2-IOxxx Output ON FGR3-IOxxx Output OFF
Options:	<ul style="list-style-type: none"> <li>Output On - Energized. Contact to ground is closed. (Conducting to GND, 2 Amps max)</li> <li>Output Off - Not energized. Contact open.</li> <li>No Change - Make no change in state when communication is lost.</li> </ul>
Terminal Menu:	(9) FGRIO Setup > (3) Digital Def1 and (4) Digital Def2
Description:	<p>Sets the state the Digital Output returns to when the device is powered up or when the device loses its link to the Master in the network.</p> <p><b>Note:</b> If programming a Digital Output to turn on after it loses a link, verify the energized device can sustain the state undamaged, in case the loss is lengthy.</p>

### 3.8.14 DO Bi-Stable

DO Bi-Stable	
Setting	Description
Default:	Constant
Options:	<ul style="list-style-type: none"> <li>Constant - The DO operates as a bi-stable digital output. <ul style="list-style-type: none"> <li>The DO remains on as long as the coil (DO1 or DO2) is set to <b>1</b>.</li> <li>The coil is NOT automatically set to <b>0</b>.</li> </ul> </li> </ul>

### 3. Configuring a Modbus I/O Slave

DO Bi-Stable	
Setting	Description
	<ul style="list-style-type: none"> <li>Auto-Off - The DO remains on for the duration set in the <b>DO Monostable Time</b> parameter or until the appropriate coil (DO1 or DO2), is set to <b>0</b>, whichever is shorter.</li> </ul>
Terminal Menu:	(9) FGRIIO Setup
Description:	<p>After the <b>DO Monostable Time</b> has elapsed, the appropriate coil is set to <b>0 (Off)</b>.</p> <p>The DO remains off until a 1 is once again written to the appropriate coil.</p>

#### 3.8.15 DO Monostable Time

DO Monostable Time	
Setting	Description
Default Setting:	0
Options:	Any number between 0 and 255.
Terminal Menu:	(9) FGRIIO Setup
Description:	<ul style="list-style-type: none"> <li>Sets the length of time the Digital Output remains on when the <b>DO Bi- Stable</b> parameter is set to <b>Auto-OFF</b>.</li> <li>The amount of time is approximately 0.15 seconds x DO Monostable Time.</li> <li>A setting of <b>0</b> causes the Digital Output to turn off at an unspecified amount of time.</li> <li>This time is always less than 0.15 seconds, but the actual time may vary.</li> </ul>

#### 3.8.16 Fast AI (DI1) and Fast AI (DI2)

**Note:** This parameter is not available in the FGRIIO-S models.

Fast AI (DI1) and Fast AI (DI2)	
Setting	Description
Default:	Fast
Options:	<ul style="list-style-type: none"> <li>Filtered - The value reported is an ongoing average of the voltage the radio receives.</li> <li>Fast - The value reported is the last sample value of the voltage the radio receives.</li> </ul>



Fast AI (DI1) and Fast AI (DI2)	
Setting	Description
Terminal Menu:	(9) FGRIIO Setup
Description:	Determines if the value reported is an ongoing average or a sample value of the voltage the radio receives.

### 3.8.17 Modbus Mode - Modbus I/O Slave

Modbus Mode	
Setting	Description
Default:	Disabled
Options:	Disabled, Enabled
Terminal Menu:	(9) FGRIIO Setup > (5) IO Modbus
Description:	<ul style="list-style-type: none"> <li>For a radio to operate as a Modbus I/O Slave, this option must be <b>Enabled</b>.</li> <li>If set to <b>Disabled</b>, the radio does not respond to Modbus polls.</li> </ul>

### 3.8.18 Modbus Address Size - Modbus I/O Slave

Modbus Address Size	
Setting	Description
Default:	8 bit
Options:	8 bit, 16 bit
Terminal Menu:	(9) FGRIIO Setup > (G) 16 Bit Modbus Address
Description:	<ul style="list-style-type: none"> <li>Set the radio for 8 bit or 16 bit Modbus addressing.</li> <li>With the <b>Modbus Address Size</b> set to: <ul style="list-style-type: none"> <li>16 bit addresses, the Modbus address can be between 1 to 65535.</li> <li>8 bit addresses, the Modbus address can between 1 and 246.</li> </ul> </li> </ul>

### 3.8.19 Modbus ID - Modbus I/O Slave

Modbus ID	
Setting	Description
Default:	246
Options:	1 to 246 (8 bit addressing) 1 to 65535 (16 bit addressing)

### 3. Configuring a Modbus I/O Slave

Modbus ID	
Setting	Description
Terminal Menu:	(9) FGRIIO Setup > (9) Modbus ID
Description:	<ul style="list-style-type: none"> <li>• Modbus ID is a user-selectable value that identifies the Modbus device.</li> <li>• Each Modbus I/O Slave acting as a Modbus device requires a unique Modbus ID.</li> </ul>

### 3.8.20 Sensor Power Default

Sensor Power Default	
Setting	Description
Default:	Enabled
Options:	<ul style="list-style-type: none"> <li>• Disabled - Upon power up, before any Modbus commands changing the Sensor Power have been received, the Sensor Power pin has no voltage applied to it.               <ul style="list-style-type: none"> <li>• In Setup Terminal, this is the <b>On</b> setting.</li> </ul> </li> <li>• Enabled - Upon power up, before any Modbus commands changing the Sensor Power have been received, the Sensor Power pin provides voltage equal to the supply voltage of the radio.               <ul style="list-style-type: none"> <li>• In Setup terminal, this is the <b>Off</b> setting.</li> </ul> </li> </ul>
Terminal Menu:	(9) FGRIIO Setup > (6) Sensor Power Default
Description:	Determines the action of the sensor power pin on the Modbus I/O Slave at power on.



## 4. Other Radio Settings

The settings described in this section are not required to establish a Modbus I/O system, but are available on the radios. Set the additional radio transmission and MultiPoint parameters in this section as needed based on the network needs.

### 4.1 Setting Other RF Transmission Characteristics

Set the following parameters in the **Transmission Characteristics** tab. These settings are available in the Edit Radio Transmission Characteristics menu in the terminal interface.

#### 4.1.1 Frequency Zones - 900MHz

**Note:** This setting only needs to be set on the I/O Master.

Frequency Zones - 900MHz	
Setting	Description
Default:	All zones selected
Options:	See below.
Terminal Menu:	(3) Edit Radio Transmission Characteristics > (0) FreqKey > F > (3) Frequency Zone
Description:	This parameter divides the available band (902 MHz to 928 MHz) into smaller bands. <ul style="list-style-type: none"> <li>• In this case 16 smaller bands each consisting of 5, 7, and 8 frequency channels are created depending on the frequency zone.</li> </ul>

Frequency Zones - 900MHz	
Setting	Description
	<ul style="list-style-type: none"> <li>• These 16 zones are stored in a Word, which is made up of 16 bits numbered 0 to 15.</li> <li>• When shown in LSB to MSB, these bits directly represent the zones that the radio operates on from lowest frequency to highest.</li> <li>• A value of <b>1</b> in the bit sequence instructs the radio to operate within the represented band.</li> <li>• A value of <b>0</b> instructs the radio to bypass the represented band.</li> </ul> <hr/> <p><b>Important!</b> This feature should only be used with the standard hop table.</p> <hr/> <ul style="list-style-type: none"> <li>• Set the <b>Hop Table Version</b> to <b>902-928 MHz</b> when using <b>Frequency Zones</b>.</li> <li>• When selecting another <b>Hop Table Version</b>, the limitations of that selection are also applied to the hopping pattern.</li> </ul> <div style="border: 1px solid gray; padding: 5px; margin-top: 10px;"> <p><b>Example:</b> If <b>916-920</b> is selected as the <b>Hop Table Version</b>, only the middle of the band is available in the pattern. Then, if Frequency Zones 5, 6, 7, 8, and 9 are set to <b>0</b>, NO allowable frequencies are available for the radio to use.</p> </div>



**Warning!** FCC regulations require a minimum of 50 separate channels be used within a hop pattern. Use the table below to determine the number of frequency zones required for legal communication.

**Example:**

Using zones 1-7 is equal to 49 channels; this is not legal according to the FCC.  
 Using Zones 0-6 is equal to 50 channels; this is legal according to the FCC.

Zone Number	Beginning Freq. (MHz)	Ending Freq. (MHz)	Number Of Channels
1	902.2464	903.8592	8
2	904.0896	905.4720	7
3	905.7024	907.0848	7
4	907.3152	908.6976	7
5	908.9280	910.3104	7

#### 4. Other Radio Settings

Zone Number	Beginning Freq. (MHz)	Ending Freq. (MHz)	Number Of Channels
6	910.5408	911.9232	7
7	912.1536	913.5360	7
8	913.7664	915.1488	7
9	915.3792	916.7616	7
10	916.9920	918.6048	8
11	918.8352	920.2176	7
12	920.4480	921.8304	7
13	922.0608	923.4432	7
14	923.6736	925.0560	7
15	925.2864	926.6688	7
16	926.8992	927.8208	5

#### Enable Frequency Zones in Tool Suite

1. In the **Tool Suite** Configuration application, select the device to program.
2. Click the **(3) Transmission Characteristics** tab.
3. Click **Frequency Zones** to view the frequency zones available.
4. Select the check boxes next to the Frequency Zones to enable.

#### Enable Frequency Zones in the Terminal Interface

1. On the main Setup menu, click **3 Edit Radio Transmission Characteristics**.
2. Select option **0 FreqKey**.
3. Select **F** for More.
4. Select option **3 Frequency Zone**.
5. Enter **1** to enable a frequency zone and **0** to disable a frequency zone. Frequency Zone entries begin with **1** (LSB) and continue through **16** (MSB).



Figure 5: Example: Frequency Zones in the Terminal Interface

### 4.1.2 Hop Table Size - 900MHz

**Important!:** All radios in a network MUST have identical **Hop Table** settings to communicate properly.

Hop Table Size - 900MHz	
Setting	Description
Default Setting:	112
Options:	50 to 112
Terminal Menu:	(3) Edit Radio Transmission Characteristics > (0) FreqKey > F > (1) Hop Table Size
Description:	Defines how many separate channels a given network uses.  <b>FreeWave Recommends:</b> Use <b>Frequency Zones</b> instead of the <b>Hop Table Size</b> setting.



**Warning!** FCC regulations require a minimum of 50 separate frequency channels be used within a hop pattern. Using the Standard hop table, a minimum of 5 frequency zones are required for legal communication.

### 4.1.3 Hop Table Version - 900MHz

**Note:** All radios in a network must have identical Hop Table settings to communicate properly.

Hop Table Version - 900MHz	
Setting	Description
Default Setting:	902-928 MHz
Options:	<ul style="list-style-type: none"> <li>● 902-911 - 919-928 MHz</li> <li>● 902-915 MHz</li> <li>● 903.744-926.3232 MHz</li> <li>● Uses 902-928 MHz with center frequencies of 911-919 MHz notched out</li> <li>● 915-928 MHz</li> <li>● 916-920 MHz</li> <li>● 902-928 MHz, full band</li> <li>● 921-928 MHz</li> </ul> <hr style="width: 50%; margin-left: 0;"/> <p><b>Important!</b> Do NOT use <b>Frequency Key E</b> (916-920 MHz) with the 915-928 MHz, 916-920 MHz, and 921-928 MHz hop tables.</p>
Terminal Menu:	(3) Edit Radio Transmission Characteristics > (0) FreqKey > F > (0) Hop Table Version
Description:	<p>Determines the section of the 900 MHz band the radio uses.</p> <p>In the terminal interface, enter the number that corresponds to the frequency band:</p>



### 4.1.4 High Noise

High Noise	
Setting	Description
Default Setting:	(0) Disabled
Options:	(0) Disabled (1) Enabled
Terminal Menu:	(3) Edit Radio Transmission Characteristics > (A) High Noise
Description:	<ul style="list-style-type: none"> <li>• Use to determine if out-of-band interference is affecting a radio link.</li> <li>• Enabling this parameter provides a reduction of gain in the front end circuit thereby decreasing the effect of any out-of- band noise.</li> <li>• The results are seen as a lower signal value and a much lower noise value (as found in Radio Statistics or Diagnostics).</li> <li>• If the noise is not reduced by a greater amount than the signal, the interference is most likely an in-band issue.</li> <li>• When a noise problem is shown to be helped using the High Noise option, chances are that the noise may be further decreased using a bandpass filter available from FreeWave.</li> </ul>

### 4.1.5 Low Power Mode

Low Power Mode	
Setting	Description
Default Setting:	0
Options:	Any number between 0 and 31.  <b>Note:</b> The higher the number, the greater the power consumption decrease.
Terminal Menu:	(3) Edit Radio Transmission Characteristics > (9) Low Power Mode
Description:	<p>Allows a MultiPoint Slave to consume less power, primarily by dimming the radio's LEDs.</p> <ul style="list-style-type: none"> <li>• When set to <b>2</b> through <b>31</b>, the radio sleeps between slots.</li> <li>• When the radio is asleep, it hears nothing from the I/O Master.</li> </ul> <p><b>Example:</b> At a setting of <b>2</b> the radio sleeps 1 out of 2 slots; at a setting of <b>3</b> the radio sleeps 2 out of 3 slots, and so on.</p> <p>This table shows the changes at different <b>Low Power Mode</b> settings. The actual current draw depends on many factors. The table below gives only a</p>

#### 4. Other Radio Settings

Low Power Mode	
Setting	Description
	qualitative indication of supply current savings. A low number reduces latency and a high number reduces current consumption.

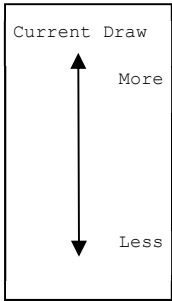
	Setting	Description
	0	Low power, disabled.
	1	LEDs dimmed, radio remains awake, radio is listening to the I/O Master's transmissions on every slot, and radio's data port is shut down if the RTS line is de-asserted (low) .  In this case, the radio needs to be awakened before it can send data to the I/O Master.
	2	LEDs dimmed, radio sleeps every other slot.
	3	LEDs dimmed, radio sleeps 2 of 3 slots.
	4-31	LEDs dimmed, radio sleeps the number of slots corresponding to the setting.  <b>Example:</b> Using a setting of 31, the radio sleeps 30 of 31 slots.

- Power savings occur only when the I/O Slave is linked.
  - No power savings occur when the I/O Slave is transmitting data.
  - Low Power Mode is of little value when a I/O Slave has a constant, high throughput.
  - **MCU Speed** must be set to **0** and **RF Data Rate** must be set to **3** for **Low Power Mode** to operate properly.
- To communicate to an RS232 port of a radio that is in **Low Power Mode**, the RTS line must be held high to wake it up.
  - The radio wakes up within approximately 20 milliseconds of when RTS goes high.
  - If the Request to Send (RTS) line on the I/O Slave is held high, the radio remains in normal operation regardless of the **Low Power Mode** setting.
  - After RTS is dropped the radio reverts to the Low Power Mode.
- If the radio has the **DTR Connect** option in the **MultiPoint Parameters** tab set to **1** or **2** and if the **Low Power Mode** is enabled (set to **1-31**), the RTS line on the radio must be asserted for the DTR Connect feature to operate properly.
- The diagnostic pins must be disabled or terminated to a cable for the Sleep current in Lower Power Mode to match the specifications.
- To disable the diagnostic pins:

- In the **Baud Rate** tab, the **Setup Port** parameter is set to **1 (Main Only)**.
- In the **MultiPoint Parameters** tab, the **Diagnostics** parameter is set to **0** (Off).
- To realize full power savings in **Low Power Mode**, the serial port must be deactivated between operation by asserting the RTS line.
  - However, because RS485/422 operation uses the RTS line as part of the data bus, it cannot be asserted to wake-up the radio.

**FreeWave Recommends:** All radios set to RS485 or RS422 use a **Low Power Mode** of **0**.

### 4.1.6 MCU Speed

MCU Speed	
Setting	Description
Default Setting:	(0) Normal
Options:	<ul style="list-style-type: none"> <li>• (0) Normal (low speed) - Reduces current consumption.</li> <li>• (1) Fast (high speed) - Required for 230 Kbaud and greater data port rate.</li> </ul>
Terminal Menu:	(3) Edit Radio Transmission Characteristics > (B) MCU Speed
Description:	Controls the speed of the Micro Controller Unit (MCU) in the radio.

### 4.1.7 Remote LED

**Note:** This feature is only available on an I/O Master.

Remote LED	
Setting	Description
Default Setting:	(0) Local Only
Options	<ul style="list-style-type: none"> <li>• (0) Local Only - Only the LEDs on the radio board are enabled.</li> <li>• (1) Remote and Local - LEDs on the radio board and remote LEDs through the diagnostic port are enabled.</li> <li>• (2) Remote Only - LEDs on the radio board are disabled. Remote LEDs through the diagnostic port are enabled.</li> </ul>
Terminal Menu:	(3) Edit Radio Transmission Characteristics > (C) Remote LED
Description:	<ul style="list-style-type: none"> <li>• If using a radio with the optional 20-pin connector, use this option to connect remote LEDs through the diagnostics port.</li> <li>• By turning off the on-board LEDs (setting = 2) the current consumption is reduced.</li> <li>• To reduce current consumption in Slaves, use <b>Low Power</b> (setting = <b>1</b>).</li> </ul>

## 4. Other Radio Settings

Remote LED	
Setting	Description
	<ul style="list-style-type: none"> <li>Remote LED drives the Diagnostic port, which has a small amount of current draw.</li> <li>When using remote LEDs, the center (TX) LED does not output a signal for a green LED when in Setup mode.</li> <li>The Green TX LED has no remote pinout.</li> </ul>

### 4.1.8 Retry Timeout

Retry Timeout	
Setting	Description
Default Setting:	255
Options:	Any number between 0 and 255.
Terminal Menu:	(3) Edit Transmission Characteristics > (8) Retry Time Out
I/O Slave Setting:	<ul style="list-style-type: none"> <li>By lowering the <b>Retry Timeout</b> setting, the inactive link time between the I/O Master and the I/O Slave can be reduced when going from autonomous mode to connecting back to the serial radio network.</li> <li>If the serial radio network Master goes down, the I/O Master and I/O Slave continues to operate in autonomous mode. <ul style="list-style-type: none"> <li>When the serial network Master comes back up, the I/O Master breaks the link with the Slave to re-establish a link with the serial network Master.</li> </ul> </li> <li>After the I/O Master is linked to the serial network Master, then the I/O Slave are able to link back to the I/O Master.</li> <li>With a lower <b>Retry Timeout</b> setting, the I/O Master is more likely to drop the link to its serial network Master when the incoming signal becomes poor.</li> </ul>

### 4.1.9 RTS to CTS

**Important!:** The RTS to CTS option is only available in RS232 mode.

It is NOT recommended to enable this feature when operating at Baud Rates above 38.4 kB.

RTS to CTS	
Setting	Description
Default Setting:	(0) Disabled
Options:	<ul style="list-style-type: none"> <li>(0) Disabled</li> </ul>

RTS to CTS	
Setting	Description
	<ul style="list-style-type: none"> <li>• (1) Enabled</li> <li>• (2) Line Alarm</li> </ul> <p>Setting 2 is described in detail in the application note #5437, DTR to CTS Line Alarm Feature.</p>
Terminal Menu:	(3) Edit Transmission Characteristics > (7) RTS to CTS
Description:	<ul style="list-style-type: none"> <li>• Use this option to set the RTS line on the Master radio to control the CTS line of the Slave. In MultiPoint networks, the Master RTS line controls all Slave's CTS lines. <ul style="list-style-type: none"> <li>• When enabled, the CTS line ceases to function as flow control.</li> </ul> </li> <li>• With <b>RTS to CTS</b> enabled, the Master senses the RTS line prior to all scheduled packet transmissions. <ul style="list-style-type: none"> <li>• If the state has changed, the Master then transmits a message to the Slave with the new status.</li> <li>• This transmission occurs regardless of data being sent. If data is ready to be sent, the RTS status message is sent in addition to the data.</li> </ul> </li> <li>• Master transmit times are completely asynchronous to the occurrence of any change of the RTS line; the latency time from RTS to CTS is variable. <ul style="list-style-type: none"> <li>• The <b>Max</b> and <b>Min Packet Size</b> parameters determine this duration.</li> <li>• Setting both parameters to their maximum value of <b>9</b> produces a maximum latency time of approximately 21 ms, given no Repeaters in the network.</li> <li>• At the minimum settings for <b>Max</b> and <b>Min Packet Size (0)</b>, the time is approximately 5.9 ms.</li> <li>• This latency can increase significantly if packets are lost between the Master and Slave.</li> <li>• In MultiPoint networks with Repeaters present, the latency is cumulative for each serial Repeater.</li> </ul> </li> <li>• If <b>DTR Connect</b> in the MultiPoint Parameters tab is enabled and set to <b>2</b>, the RTS to CTS feature does not work. <ul style="list-style-type: none"> <li>• If <b>DTR Connect</b> is enabled and set to <b>1</b>, RTS to CTS mode takes precedence over the functionality of the CTS line on the Slave relating to the <b>DTR Connect</b> feature.</li> </ul> </li> </ul>

#### 4. Other Radio Settings

### 4.1.10 Slave Security

Slave Security	
Setting	Description
Default Setting:	(0) On
Options:	(0) On (1) Off
Terminal Menu:	(3) Edit Transmission Characteristics > (6) Slave Security
Description:	<ul style="list-style-type: none"> <li>In a wire replacement I/O system, leave this parameter set to <b>On</b>.</li> <li>A setting of <b>On</b> means only the Master listed in the I/O Slave's call book can link to that slave.</li> </ul>

### 4.1.11 Transmit Power

Transmit Power	
Setting	Description
Default Setting:	10
Options:	Any number between 0 and 10.
Terminal Menu:	(3) Edit Transmission Characteristics > (5) RF Xmit Power
Description:	<ul style="list-style-type: none"> <li>Sets the output power of the radio.</li> <li>A setting of 10 is approximately 1 W of output power.</li> </ul> <hr/> <p><b>FreeWave Recommends:</b> In a wire replacement application, use a low setting, such as 2 or 3 because the signal does not likely need to travel a great distance.</p> <ul style="list-style-type: none"> <li>With a higher power setting with radios within close range can increase the amount of noise in the system.</li> <li>When testing radios that are in close proximity to one another, set the <b>Transmit Power</b> to a low number.</li> <li>When deploying radios to the field, raise the <b>Transmit Power</b> number accordingly.</li> </ul>

---

**Important!:** This table is for reference only. All **Transmit Power** settings between **0** and **9** are approximate.

---

Setting	Transmit Power (in mW)
0	5
1	10
2	35
3	80
4	140
5	230
6	330
7	480
8	600
9	800
10	1000

### 4.1.12 Transmit Rate

Transmit Rate	
Setting	Description
Default Setting:	(1) Normal
Options:	(0)Diagnostics (1)Normal
Terminal Menu:	(3) Edit Transmission Characteristics > (3) Xmit Rate
Description:	<p>The setting for normal operation of the radio is <b>1</b>.</p> <ul style="list-style-type: none"> <li>When set to <b>0</b>, the radios transmit back and forth continuously regardless of if they have any actual data.</li> <li><b>0</b> should only be used as a diagnostic tool and not for normal operation.</li> <li>The strength of the signal may be gauged by the Clear to Send (CTS) LED.</li> <li>A solid red CTS LED indicates a strong signal.</li> <li>A blinking CTS LED indicates a weaker signal.</li> </ul>

## 4.2 Setting Other MultiPoint Parameters

Set these parameters in the **MultiPoint Parameters** tab. These settings are available in the MultiPoint Parameters menu in the terminal interface .

### 4.2.1 1 PPS Enable Delay

1 PPS Enable Delay	
Setting	Description
Default Setting:	255
Options:	255 to disable 1 PPS 0 to 254 to enter the delay
Terminal Menu:	(5) Edit MultiPoint Parameters > (9) 1 PPS Enable/Delay
Description:	The 1 PPS Enable/Delay setting allows a 1 PPS signal to propagate from the I/O Master to all I/O Slaves in a MultiPoint network. When this parameter is enabled a properly generated pulse applied on the DTR line of the I/O Master provides a 1 PPS pulse on the CD line of any I/O Slave in the network.  Follow the steps below to use the 1 PPS Enable/Delay feature.

#### Setup 1PPS Enable/Delay

1. Set the **1 PPS Enable/Delay** parameter to **0** in the Master.

**Note:** The I/O Master must have a 1 PPS pulse on the DTR pin.

2. Enable the **1 PPS Enable/Delay** parameter on the I/O Slaves.

#### Calibrate an I/O Slave in 1PPS Enable/Delay Mode

1. Trigger an oscilloscope on the 1 PPS pulse on the DTR line of the I/O Master.
2. Monitor the CD line of the I/O Slave.
3. If the timing on the I/O Slave differs from the I/O Master it may be adjusted using the value in the I/O Slave's **1 PPS Enable/Delay** parameter. The difference in time between each incremental integer value is 542.534 ns. Changing the parameter to higher values decreases the I/O Slave time delay and changing the parameter to lower values increases the time delay.

When properly calibrated, the CD line I/O Slave radio outputs a pulse that goes high for about 2 ms in sync with the 1 PPS pulse on the I/O Master. The output on the I/O Slave occurs within 20 microseconds of the input to the I/O Master.

---

**Important!:** When **1 PPS** is enabled, the I/O Master must have a 1 PPS pulse on its DTR pin, otherwise the RF network does not function.

---



## 4.2.2 Diagnostics

Diagnostics	
Setting	Description
Default Setting:	0 (Disabled)
Options:	Any number between 0 and 128
Terminal Menu:	(5) Edit MultiPoint Parameters > (B) Diagnostics
Description:	<ul style="list-style-type: none"> <li>Allows diagnostics data in the Network Diagnostics application within <b>Tool Suite</b> to be viewed at the I/O Master in parallel with application data.</li> <li>The setting in this parameter determines how many slots out of 128 are dedicated to diagnostics.</li> </ul> <p><b>Example:</b> If set to 10, 1 out of every 10 data slots is for diagnostics data; if set to 100, 1 out of every 100 data slots is for diagnostics data.</p> <p><b>Note:</b> Diagnostics is always secondary to actual transmitted data.</p>

## 4.2.3 DTR Connect

DTR Connect	
Setting	Description
Default Setting:	(0) Off
Options:	<ul style="list-style-type: none"> <li>(0) Off - When set to off in the Slave, the radio transmits when the data is received.</li> <li>(1) DTR Sensing - Forms a Point-to-Point link with the I/O Master when the DTR line is high to send data.</li> <li>(2) Burst Mode - The radio transmits data in bursts.</li> </ul>
Terminal Menu:	(5) MultiPoint parameters > (4) DTR Connect
Description:	<ul style="list-style-type: none"> <li>Determines how the radio sends its data. <ul style="list-style-type: none"> <li>This mode is valuable when a network has many low data rate devices and you want to increase overall network capacity.</li> </ul> </li> <li>If <b>DTR Connect</b> is set to <b>1</b> and the <b>RTS to CTS</b> function is enabled on the radio, then <b>RTS to CTS</b> takes precedence over <b>DTR Connect</b>.</li> <li>If <b>DTR Connect</b> is set to <b>2</b> and <b>RTS to CTS</b> is enabled, then <b>RTS to CTS</b> is ignored. <ul style="list-style-type: none"> <li>The radio has two separate transmit and receive user data buffers.</li> <li>These buffers are 2 Kbytes each. In case of a buffer overflow, the radio outputs unpredictable data.</li> </ul> </li> </ul>

## 4. Other Radio Settings

### 4.2.4 Local Mode

**Note:** This parameter does not apply in a Modbus I/O system.

### 4.2.5 Max Slave Retry

Max Slave Retry	
Setting	Description
Default Setting:	9
Options:	Any number between 0 and 9.
Terminal Menu:	(5) Edit MultiPoint Parameters > (2) Max Slave Retry
Description:	<ul style="list-style-type: none"><li>• Defines how many times the I/O Slave attempts to retransmit a packet to the I/O Master before beginning to use a back-off algorithm (defined by the <b>Retry Odds</b> parameter).</li><li>• I/O Slave retries stop when the I/O Slave receives an acknowledgment from the I/O Master.</li></ul>

### 4.2.6 Multi-Master Sync

The **Multi-Master Sync** setting is reserved for applications with concentrations of Master units where it is necessary to reduce interference between the Masters.

**Note:** This setting does not apply because a wire replacement I/O system has only one Master and does not apply to **FGR3-IO-IOE** nor **FGR3-IO-C-U**

### 4.2.7 Radio ID

Radio ID	
Setting	Description
Default Setting:	Blank
Options:	Any 4 digit, user-defined number.
Terminal Menu:	(5) Edit MultiPoint Parameters > (D) Radio ID
Description:	Use this option to designate a radio with an arbitrary, user-defined, 4-digit number that identifies the radio in Diagnostics mode.

## 4.2.8 Radio Name

Radio Name	
Setting	Description
Default Setting:	Blank
Options:	Any combination of letters or numbers up to 20 characters
Terminal Menu:	(5) Edit MultiPoint Parameters > (G) Radio Name
Description:	<ul style="list-style-type: none"> <li>Use this parameter to give a radio a name, such as its location.</li> <li>Naming radios can be helpful to identify a radio when in Diagnostics mode.</li> </ul>

## 4.2.9 Repeater Frequency

**Repeater Frequency** is used when a parallel Repeater is present.

**Note:** This setting does not apply to an I/O Master or an I/O Slave because a wire replacement I/O system cannot contain Repeaters.

## 4.2.10 Retry Odds

Retry Odds	
Setting	Description
Default Setting:	0
Options:	Any number between 0 and 9.
Terminal Menu:	(5) Edit MultiPoint Parameters > (3) Retry Odds
Description:	<ul style="list-style-type: none"> <li>While packets transmitted from the I/O Master to the I/O Slaves are NOT acknowledged, packets transmitted from I/O Slaves to the I/O Master are acknowledged.</li> <li>It is possible that more than one I/O Slave attempts to transmit to the I/O Master at the same time.</li> <li>Therefore, it is important that a protocol exists to resolve contention for the I/O Master between I/O Slaves.</li> <li>This is addressed through the <b>Max Slave Retry</b> and <b>Retry Odds</b> parameters.</li> <li>After the I/O Slave has unsuccessfully attempted to transmit the packet the number of times specified in the <b>Max Slave Retry</b> parameter, it attempts to transmit to the I/O Master on a random basis.</li> </ul>

## 4. Other Radio Settings

Retry Odds	
Setting	Description
	<ul style="list-style-type: none"><li>The <b>Retry Odds</b> parameter determines the probability that the Slave attempts to retransmit the packet to the I/O Master; a low setting assigns low odds to the I/O Slave attempting to transmit.</li><li>Conversely, a high setting assigns higher odds.</li></ul> <p><b>Example:</b> Consider two different I/O Slaves in a MultiPoint network, one with a strong RF link and the other with a weak RF link to the I/O Master.</p> <p>If an I/O Slave has a weak or poor link, set <b>Retry Odds</b> to <b>0</b> as it may become a "chatty" Slave and lockup the network, causing a loss of communication data.</p> <ul style="list-style-type: none"><li>When <b>Retry Odds</b> is set to <b>0</b>, after the I/O Slave has exhausted the number of retries set in the <b>Max Slave Retry</b> parameter and still not gained the I/O Master's attention, the I/O Slave's data buffer is purged.</li></ul> <hr/> <p><b>FreeWave Recommends:</b> A <b>Retry Odds</b> set to <b>0</b> is recommended for most networks.</p>

### 4.2.11 Slave/Repeater

The **Slave/Repeater** parameter allows a radio to switch between Slave and Repeater functions.

---

**Important!:** This parameter must remain set to **Disabled** because a wire replacement I/O system cannot contain a Repeater.

---

## 4.3 Reading Diagnostics in Tool Suite

The **Network Diagnostics** application is used to view diagnostic data for all the devices connected to the Master in the network in real time. This application is NOT meant to replicate the functionality of an NMS system, but rather it is a tool that can be used for diagnostics and troubleshooting in the field.

---

**Important!:** The **Network Diagnostics** application is intended for occasional network monitoring or troubleshooting, not for continuous, long-term collection of diagnostic data.

---

This section provides basic steps for reading diagnostics using **Tool Suite**. **Tool Suite** stores the diagnostic data in the database and you can import or export a diagnostic file.

For information regarding the data available, recommended best practices, and importing and exporting files using the Network Diagnostics application, see the **Tool Suite User Manual**.

**Note:** To help identify the radios in the network when running **Network Diagnostics**, set the **Radio Name** and **Radio ID** fields in the MultiPoint Parameters tab.

**Important!:** The diagnostic program **MUST** be run from the Master radio.

Diagnostics requires these settings:

- A setting in the Diagnostics parameter on the Master between 1 and 128.
- A second computer or serial connection to run the diagnostics software.
- A diagnostics cable (Available from [www.freewave.com](http://www.freewave.com).)
- Diagnostics software (Available from [www.freewave.com](http://www.freewave.com).)

For more information about Diagnostics, see [Contacting FreeWave Technical Support \(on page 14\)](#).

## Procedure

1. Connect the Master to the computer running **Tool Suite**.
2. Open **Tool Suite** and click **Network Diagnostics** in the Applications pane.
3. Click the list box arrow in the Networks section of the ribbon and select the serial network to run diagnostics on.

**Note:** If there is no network defined, click **Add** and follow the instructions in the wizard.

4. On the ribbon, click **Start**.
5. To stop running diagnostics, click **Stop**.

**Note:** If you move away from the Network Diagnostics application without selecting Stop, the program continues to poll for diagnostic data.

**Important!:** **Tool Suite** is NOT optimized for the collection and management of large amounts of diagnostic data from continuous polling. Collection of excessive amounts of data results in overall performance degradation in **Tool Suite** and network throughput degradation.

## **5. Installing and Wiring Components**

---

Use the information in this section to wire an I/O Master to a device such as an RTU and to wire an I/O Slave to an end device such as pressure sensor or switch.

Any of the examples in this section can also be expanded using the I/O expansion modules available to increase the number of I/O terminal ports available on an I/O Slave.

**Example:** If the well site has multiple tanks or multiple sensors that exceed the ports available on the I/O Slave.

### **5.1 Wiring Modbus I/O Slaves**

- The terminal block on the Modbus I/O Slave can accept a single wire up to 16 gauge.
- Smaller wire is required for 2 wires, or wire and resistor connected into the same screw terminal.

#### **5.1.1 Radio Power**

Power is available on screw terminal #11 (B+ In) of the Modbus I/O Slave terminal block or through Pin 1 on the 10-pin header connector.

Use either to power the Modbus I/O Slave. Pin 1 on the connector is the pin closest to the edge of the board and Pin 10 is closest to the inside of the board.

#### **5.1.2 Digital Inputs**

Complete these steps when connecting the Modbus I/O Slave to a digital end device, such as a pressure switch:

1. Connect the end device output wire to Digital Input 1 screw terminal # 1 or Digital Input 2 screw terminal # 2 on the terminal block of the Modbus I/O Slave.
2. Connect the ground wire from the end device to Ground screw terminal # 3, 9, or 12 on the terminal block of the Modbus I/O Slave.  
If the Ground wire is not returned to the radio, the potential difference between the radio's Ground and the end device Ground should not exceed 1 V.
3. If wiring a 3-wire digital transducer, set up similarly to the 1-5 V analog sensor, except connect the signal wire to a Digital Input.

### 5.1.3 Digital Outputs

When connecting the Modbus I/O Slave outputs to a digital end device:

- Connect the appropriate terminal on the device to DO1 (terminal # 4) or DO2 (terminal # 5).
- Power the external device from the same power source as the Modbus I/O Slave.
- Use Modbus commands to turn the digital output On and Off.
  - When the output is turned on, it sinks up to 2 Amps to ground.
  - When the output is turned off, the output is floating.

## 5.2 Wiring Modbus I/O Slaves to 4-20 mA Sensors

A common measurement interface for sensing equipment is a 4-20 mA current output.

- The current amplitude correlates to a specific measurement (pressure, temperature, flow rate, etc.).
- The information in this section provides details for wiring the Modbus I/O Slaves Analog Inputs to 4-20 mA sensors, including details about installing external resistors required to convert the signal to 1 to 5 V.

### 5.2.1 Connecting a 4-20 mA Sensor to Analog Input 1 or Analog Input 2

This procedure is used when connecting a 4-20 mA sensor to Analog Input 1 or Analog Input 2 on a Modbus I/O Slave.

---

**Important!:** A resistor (249  $\Omega$  or 250  $\Omega$ ) is required to convert 4-20 mA from the sensor to 1-5 V.

---

#### Procedure

1. If using a board-level I/O Slave, place the resistor between the Analog Input (terminal #8 or #10) and the Ground screw terminal (terminal #6, #9 or #12) of the I/O Slave.

## 5. Installing and Wiring Components

**Note:** The resistor produces a 1-5 V signal across it when 4-20 mA flows through it. If using an **FGR2-IOS-CE-U** (ruggedized enclosure), a resistor exists within the radio to enable or disable. This resistor takes the place of an inline resistor.

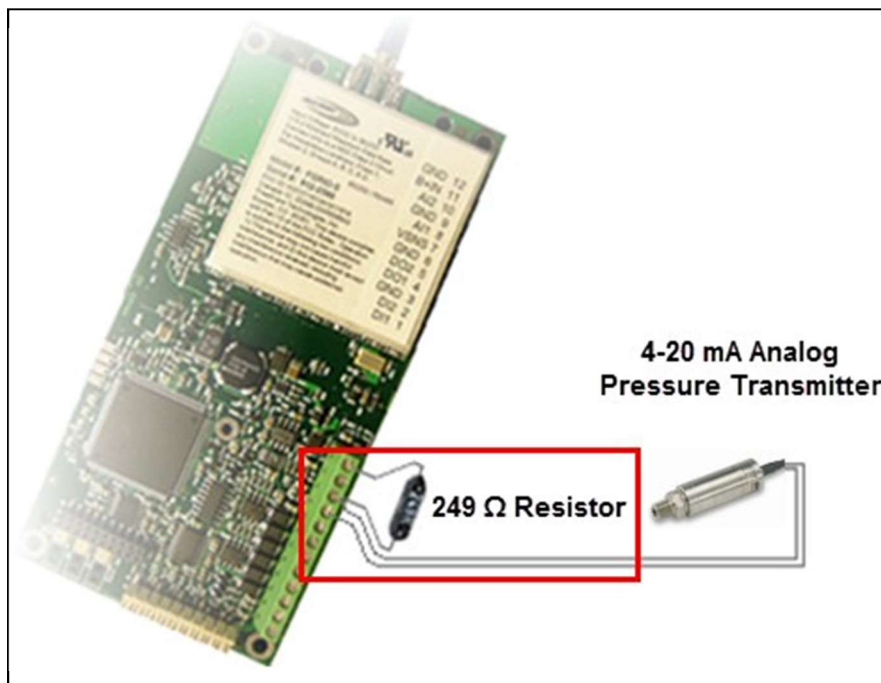

**Figure 6: Example: 249  $\Omega$  Resistor**

2. Enable the resistor between the 4-20 mA sensor and the analog input using the **AI1 250 Ohms** or **AI2 250 Ohms** parameter in the **Modbus Settings** tab in **Tool Suite**.

**Note:** The internal resistor powers on after the radio powers on and boots up.

**Important!:** Verify the correct radio voltage is supplied.

3. Connect the Sensor Power Supply (High) wire to VSNS screw terminal #7 on the terminal block of the I/O Slave.
4. Connect the Sensor Output (Low) wire to the same Analog Input (terminal #8 or #10) as the resistor on the terminal block of the I/O Slave.

This diagram illustrates a board-level wiring installation.



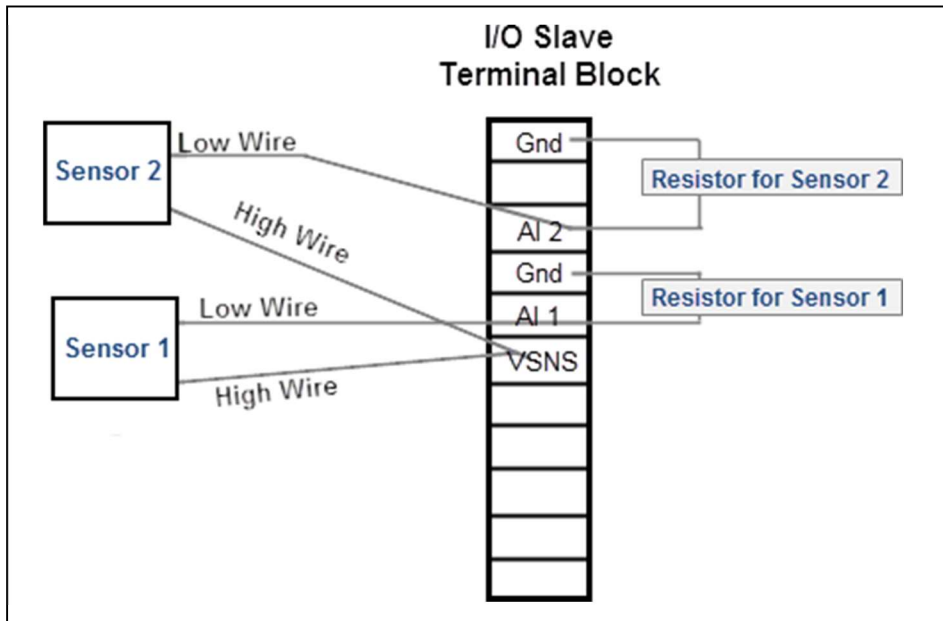

Figure 7: Board-level Wiring Installation

### 5.2.2 Connecting a 4-20 mA Sensor to Analog Input 3 or Analog Input 4

The same accuracy and signal level reduction considerations stated in [Connecting 1-5 Volt Sensor to Analog Input 3 or Analog Input 4 \(on page 84\)](#) apply when using a 4-20 mA sensor. The switched voltage source at screw terminal #7 is designed to drive only two 4-20 mA transmitters to full scale.

**Note:** If a system uses more than two, power the additional transmitters from a separate supply, such as directly from the battery or another DC supply.

This diagram illustrates the connection of a 4-20 mA sensor to Analog Input 3, with half the typical resistor:

## 5. Installing and Wiring Components

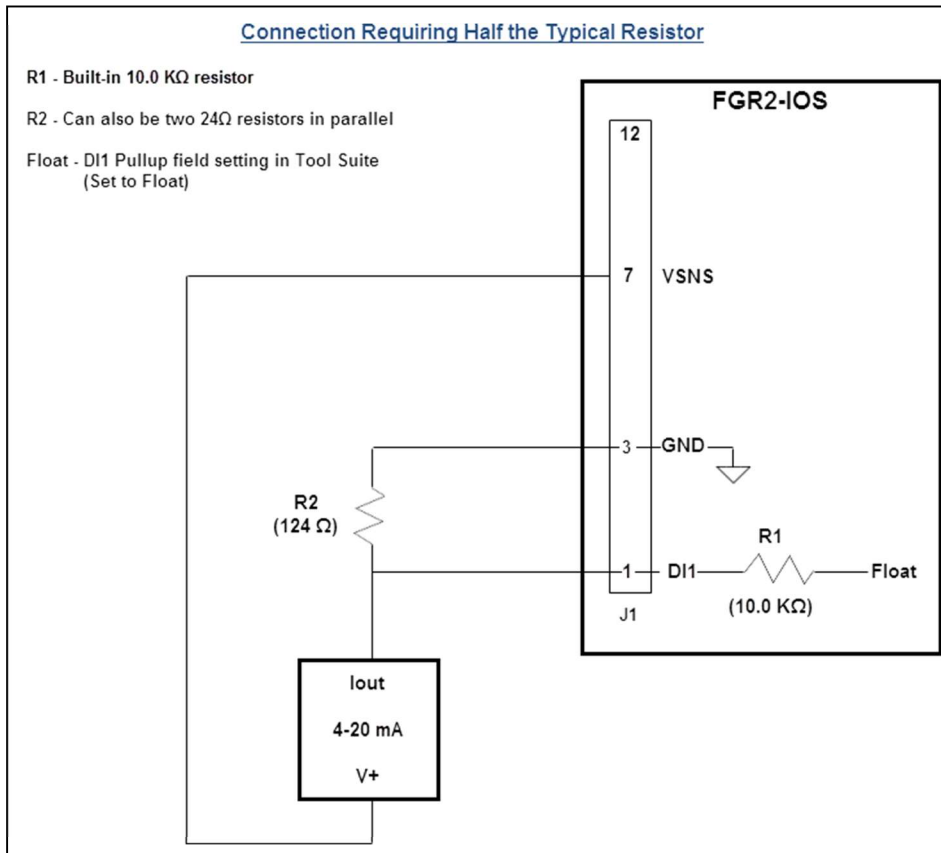

**Figure 8: Connection of a 4-20 mA Sensor to Analog Input 3, with Half the Typical Resistor**

This diagram illustrates the connection of a 4-20 mA sensor to Analog Input 3 requiring an approximately 250 ohm load:

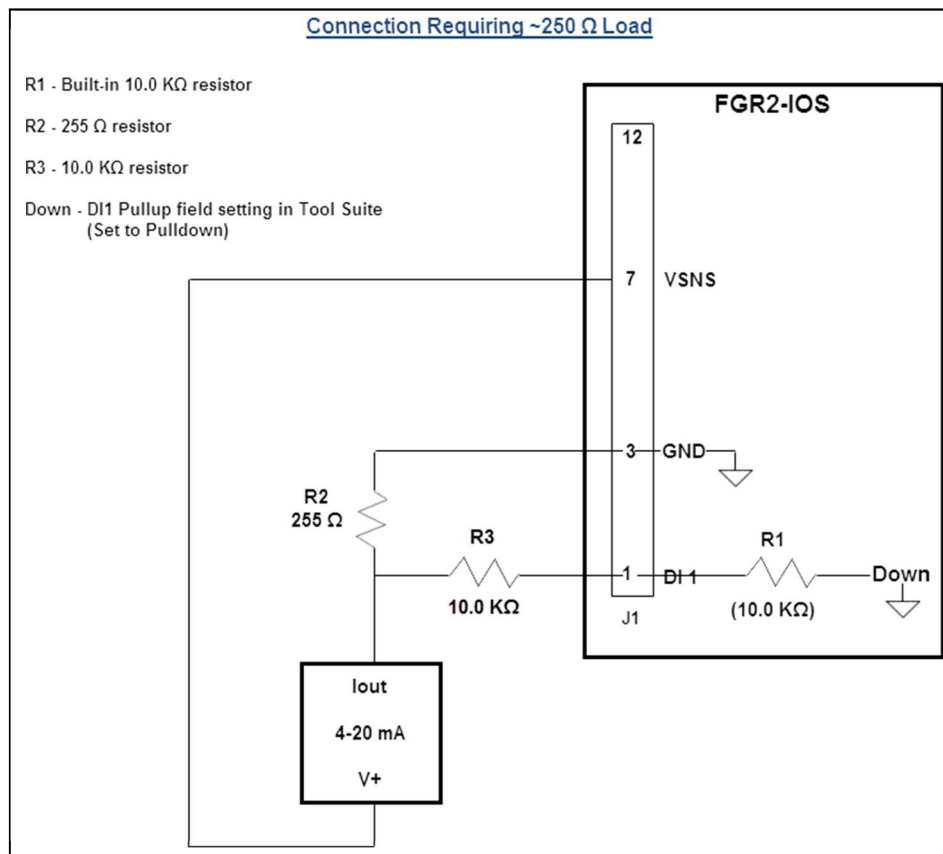

**Figure 9: Connection of a 4-20 mA Sensor to Analog Input 3 Requiring an Approximately 250 Ohm Load**

## 5.3 Wiring Modbus I/O Slaves to 1-5 V Sensors

The information in this section provides details for wiring the Modbus I/O Slaves Analog Inputs to 1-5 V sensors.

### 5.3.1 Connecting a 1-5 Volt Sensor to Analog Input 1 or Analog Input 2

- Analog Input 1 or Analog Input 2 screw terminal #8 and #10 are usable with 0.1 V to 5.625 V input voltages (compatible with most 1-5 V and 4-20 mA transmitters) and load the input with about 100 K $\Omega$  to GND.
- They also offer accuracy of  $\pm 0.1\%$  with 16-bit resolution and are recommended for the most critical variables in a system.

## 5. Installing and Wiring Components

**Note:** If using an FGR2-IOS-CE-U, ensure the **AI1 250 Ohms** and **AI2 250 Ohms** settings in the Modbus Settings tab in Tool Suite are disabled. The internal resistor is not required when connecting to a 1-5 V sensor.

Use a 3-wire connection to connect a 1-5 V sensor to either Analog Input 1 or Analog Input 2 on the I/O Slave.

1. Connect the sensor's Ground wire to Ground screw terminal #3, 9, or 12 on the terminal block of the Modbus I/O Slave.
2. Connect the sensor's Power wire to the VSNS screw terminal #7 on the terminal block of the I/O Slave. Rated total current draw from VSNS is 40 mA or less.
3. Connect the sensor's output wire to Analog Input 1 or Analog Input 2 screw terminal #8 and #10.

### 5.3.2 Connecting 1-5 Volt Sensor to Analog Input 3 or Analog Input 4

- The Digital Inputs on the Modbus I/O Slave may be digitized to 10-bit resolution and read directly by the Modbus.
- This allows up to four analog transducers to be connected to a single remote Modbus I/O Slave.

**Note:** In the FGRIIO-S radio, this feature requires firmware version of 2.65IO or higher.

- The Analog Inputs formed from the Digital Inputs at screw terminal #1 and screw terminal #2 are directly usable with signals only from 0.1 V to 2.812 V. Input loading can be selected as 10 K $\Omega$  to GND or unloaded (>1 M $\Omega$ ).
- The DI accuracy is within +/- .25% and resolution is 10-bits.

### 5.3.3 1-5 Volt Sensor Signal Coupling for Analog Input 3 and Analog Input 4

For the Analog Input 3 and Analog Input 4:

- **Input Resistor** - The I/O Slave Digital Inputs provide an internal 10 K $\Omega$  resistor pull-up to the radio's 3.3 V logic supply.
  - With firmware 2.25IO and later, the resistor can also be commanded to pull down to GND or "float" unconnected.
  - See [DI1 Pullup and DI2 Pullup \(on page 54\)](#)



**Tip:** These options are useful for Analog Input connections.

- **Signal Level Reduction** - Digital Inputs #3 and #4 do not have sufficient voltage range for direct connection to typical transducer outputs, so the input must be restricted.

- In Modbus, the voltage at the DI is simply digitized for a subsequent register poll.
- **VSNS Sensor Power** - The switched voltage source at screw terminal #7 is designed to drive only two 4-20 mA transmitters to full scale.
- Voltage output (1-5 V) transmitters usually consume less current and may allow up to four to be switched.

This diagram illustrates the connection of a 1-5 V transmitter to Analog Input #3:

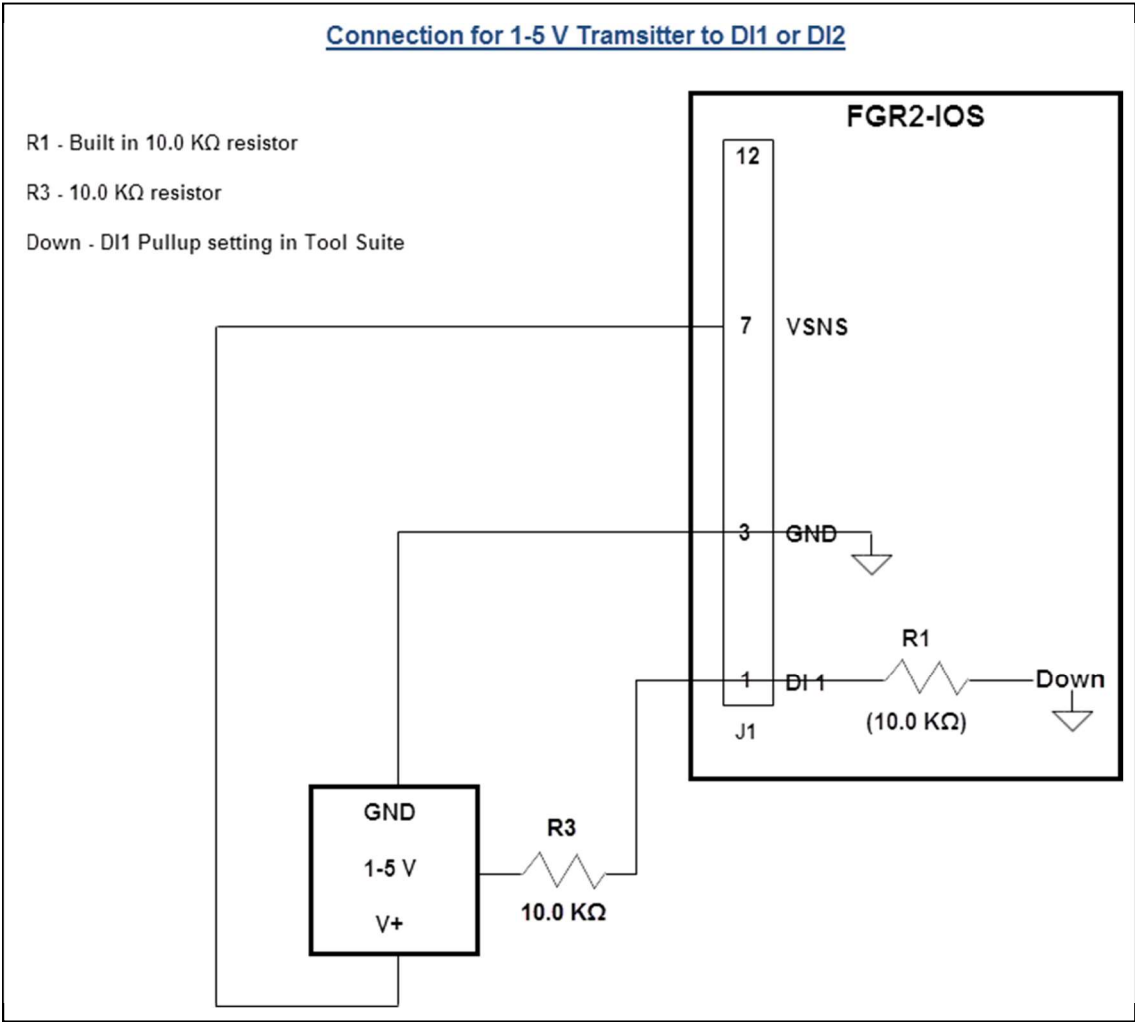

**Figure 10: Connection of a 1-5 V Transmitter to Analog Input #3**

## 5. Installing and Wiring Components

This diagram illustrates the connection of a 1-5 V transmitter requiring 100 K $\Omega$  load:

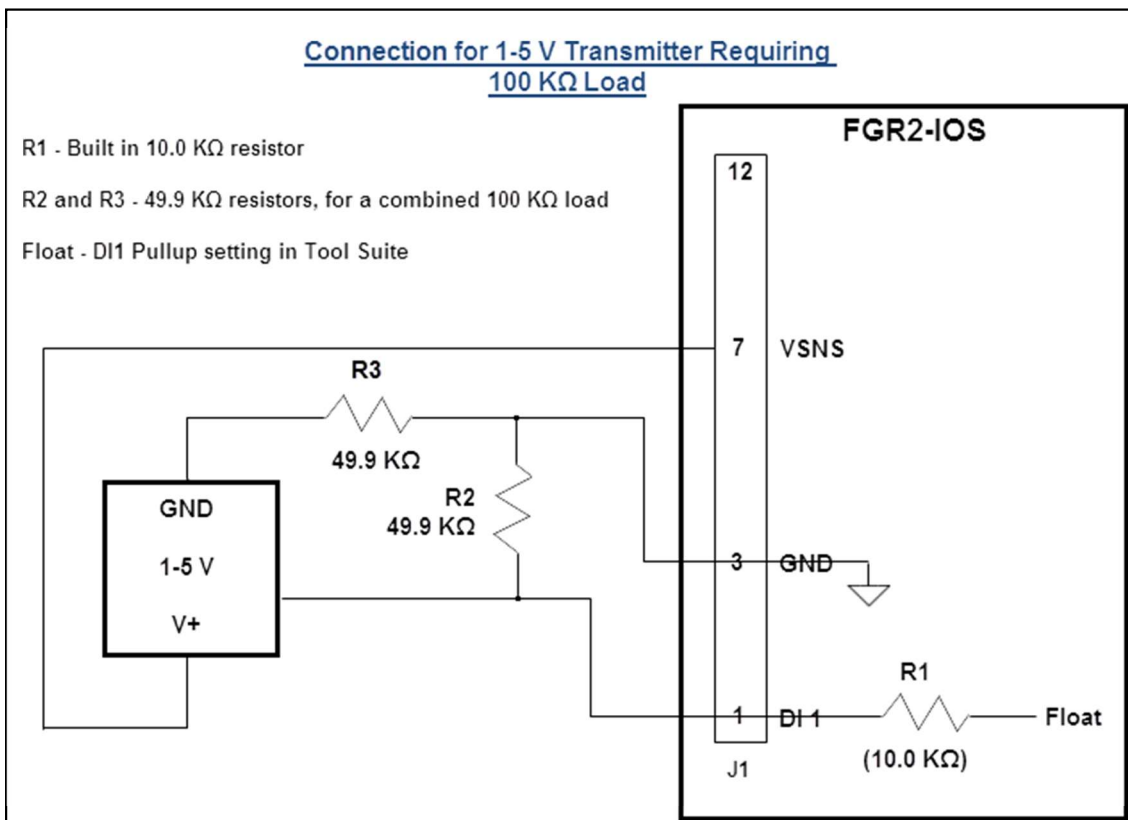

Figure 11: Connection of a 1-5 V Transmitter Requiring 100 K $\Omega$  Load

### 5.4 Using an Analog Input as a Digital Input with a Pullup Resistor

If an additional digital input is needed and an analog input is available on the Modbus I/O Slave, use a pullup for the analog input to act as a digital input. This example illustrates using AI1 as a digital input to a switch.



**Tip:** Replicate the behavior on the additional analog inputs available on the board.

- When using a 24 V power supply, float the analog input at 4.8 VDC.
  - The Modbus register reads 1.
  - When the switch closes, the Modbus register reads 0.
- When using a 24 V power supply, float the analog input at 2.4 VDC.
  - The Modbus register reads 1.
  - When the switch closes, the Modbus poll register 0.

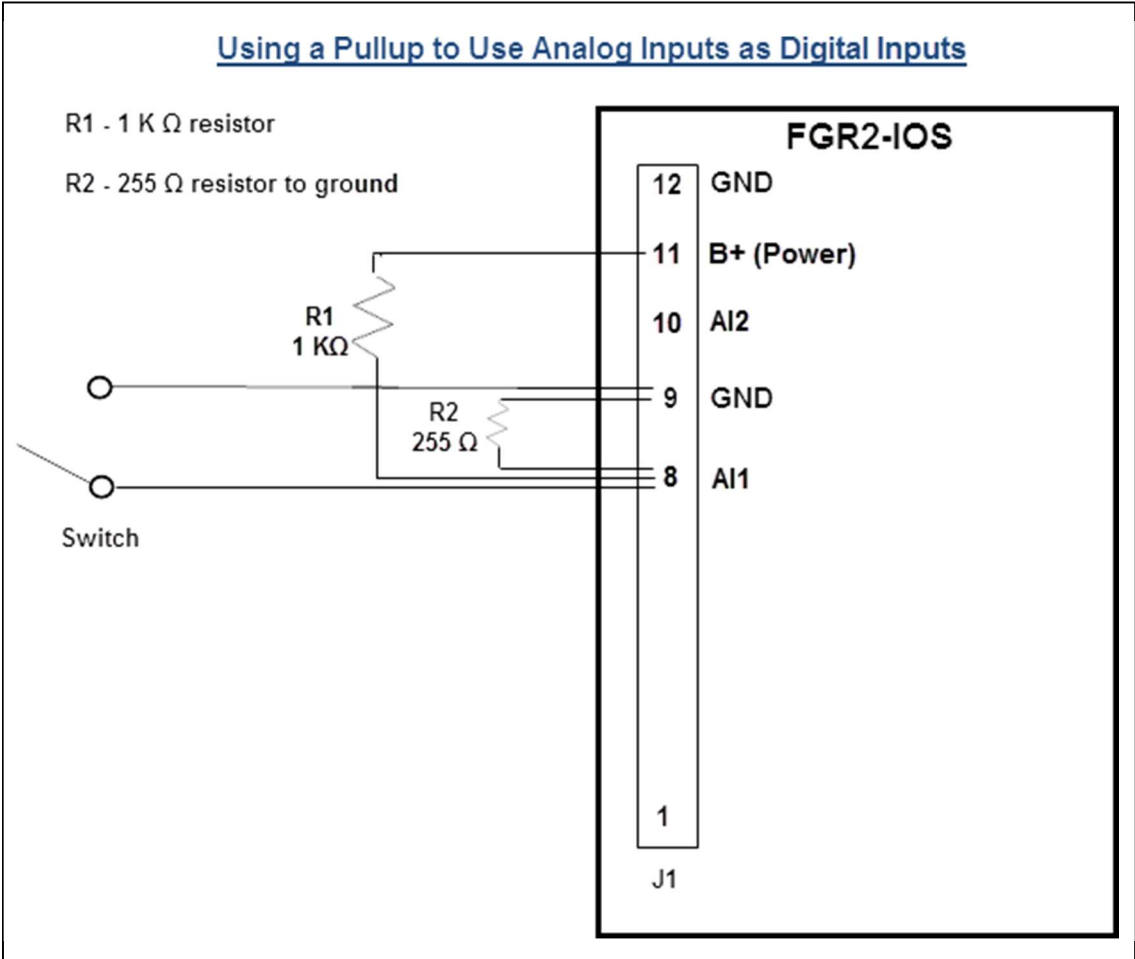

**Figure 12: Using an Analog Input as a Digital Input with a Pullup Resistor**

## 5.5 Plunger Lift Example

The following example illustrates the Modbus setup to control plunger lift at a well head using a single Modbus I/O Slave.

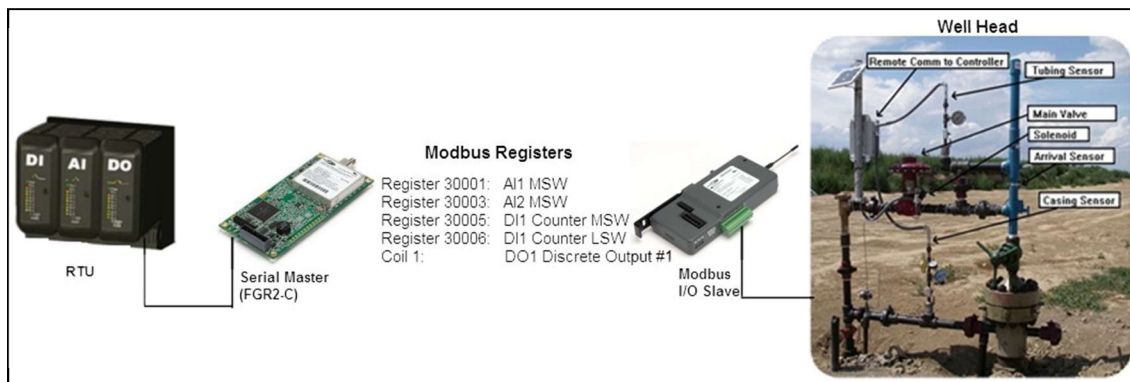
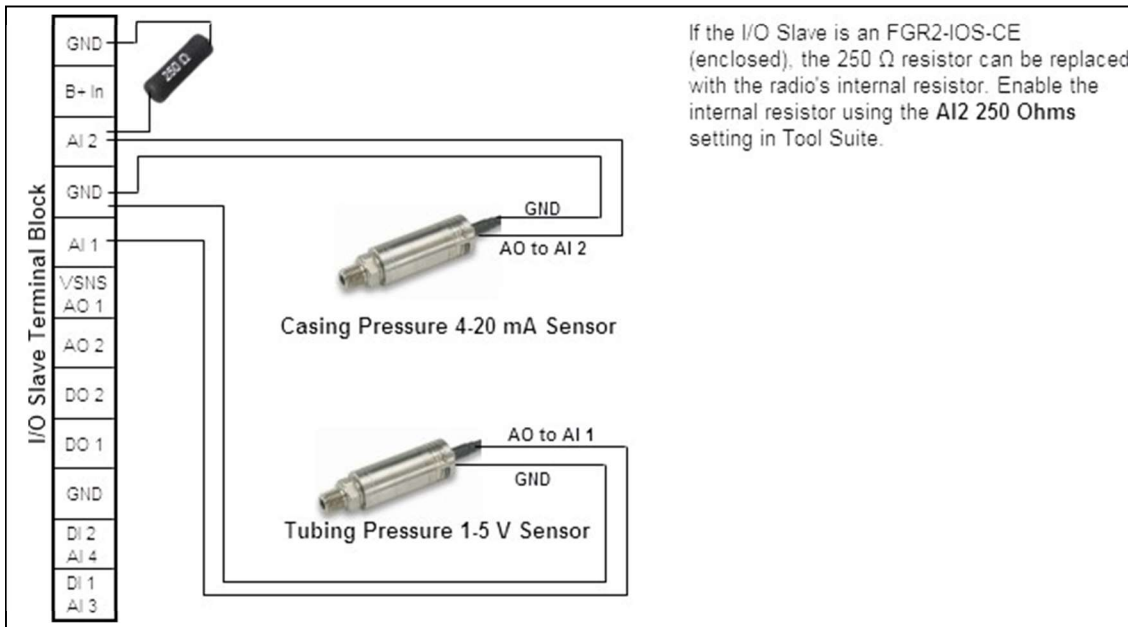

Figure 13: Example: Plunger Lift

### 5.5.1 Modbus I/O Slave to the Well Head

- Wire the terminal ports on the I/O Slave to the casing pressure sensor and the tubing sensor.
- Wire each sensor to ground.
- The resistor is used to convert the 4-20 mA signal to a 1-5 V signal that is readable at the serial Master.





**Figure 14: Wire the terminal ports on the I/O Slave to the casing pressure sensor and the tubing sensor.**

Wire the terminal ports on the I/O Slave to the solenoid valve and the plunger arrival sensor. Wire each sensor to ground.

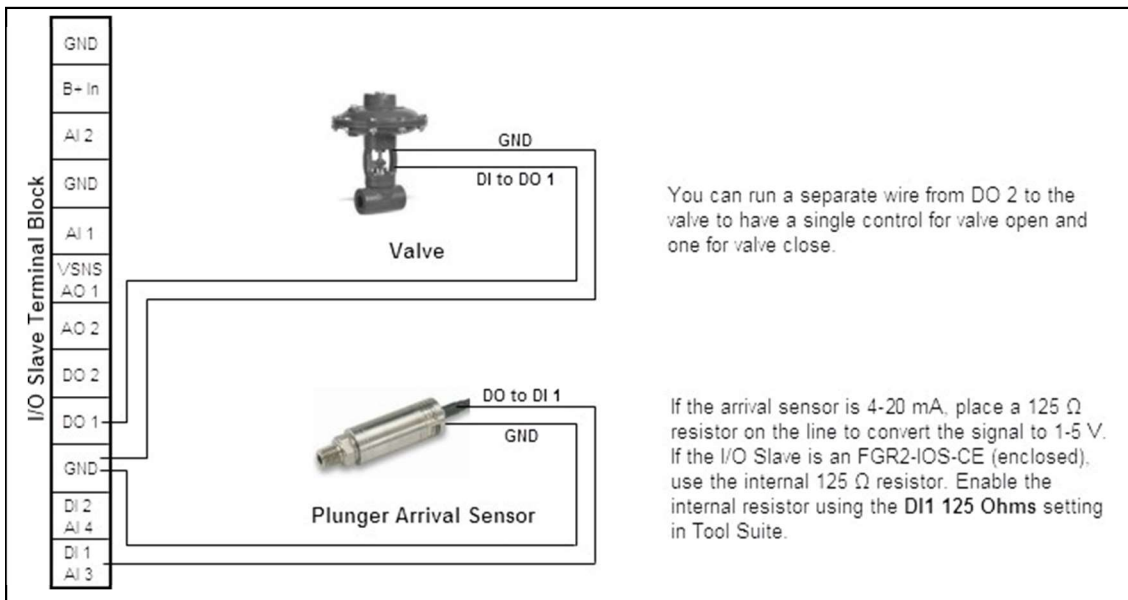

**Figure 15: Wire the terminal ports on the I/O Slave to the solenoid valve and the plunger arrival sensor.**

## 5.5.2 Modbus Registers

Ensure that both the serial Master and the Modbus I/O Slave are configured as described in the other sections within this manual and that the Master can connect to the Slave.

**Note:** The registers and coils in this example use the PLC addressing method.

Use the following Modbus registers and coils for this plunger list example.

- Input Register 30001 AI1 MSW - To read the tubing pressure on Slave AI1.
- Input Register 30003 AI2 MSW - To read the casing pressure on Slave AI 2.
- Coil 1 DO1 Discrete Output #1 - To control the solenoid valve on Slave DO1.
- Input Register 30005 DI1 Fault - To read plunger arrival sensor on Slave DI1. To read and clear the counter, use Input Register 30005 DO1 Fault and Input Register 30006 DI1 Counter LSW.

## 5.6 Tank Level Example

This example illustrates the wire replacement setup to measure tank level:

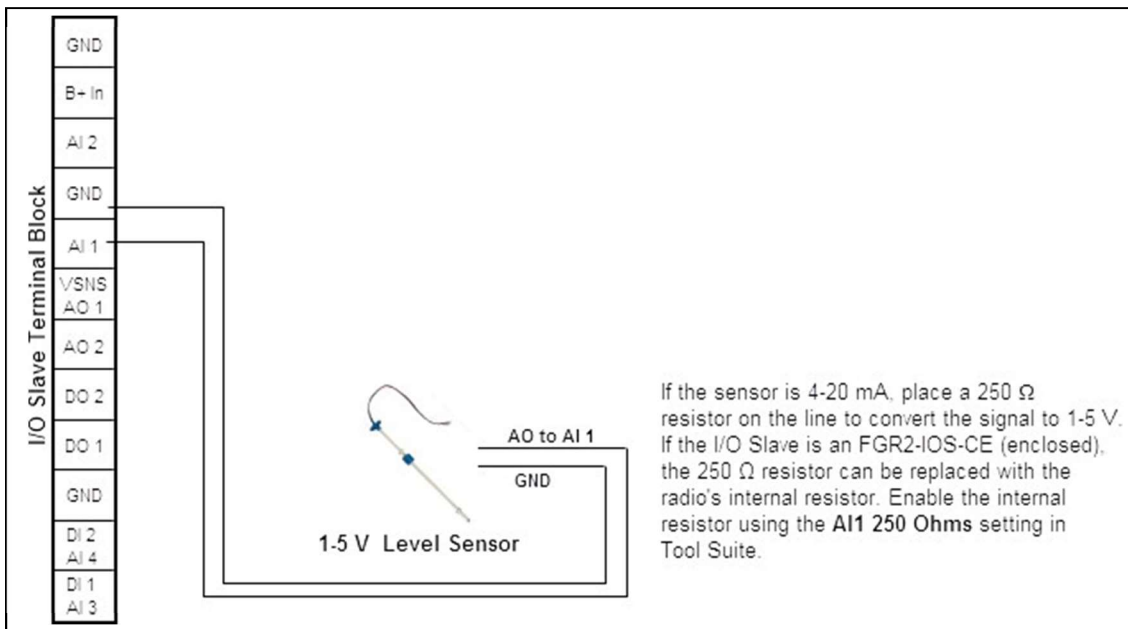

**Figure 16: Example of wire replacement setup to measure tank level.**

**Note:** Each wiring and setup portion of the above illustration is detailed in the sections below.

### 5.6.1 Modbus I/O Slave to the Well Head

Wire the terminal ports on the Modbus I/O Slave to the sensor and wire the sensor to ground.



**Figure 17: Wire the terminal ports on the Modbus I/O Slave to the sensor and wire the sensor to ground.**

### 5.6.2 Modbus Registers

1. Verify both the Modbus I/O Master and the Modbus I/O Slave are configured as described in the other sections within this manual and that the Master can connect to the Slave.
2. Use Input Register 30001 AI1 MSW to measure the tank level on Slave AI1.

## 5.7 Tubing Pressure Example

This example illustrates the wire replacement setup for a tubing pressure sensor.

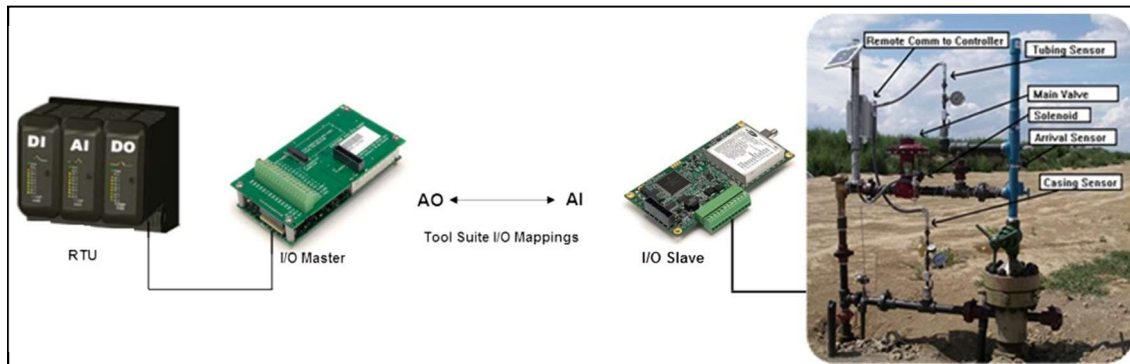

Figure 18: Example: Wire Replacement Setup for a Tubing Pressure Sensor

### 5.7.1 I/O Master to the RTU

Wire the AO1 to RTU Analog Input for the tubing sensor.

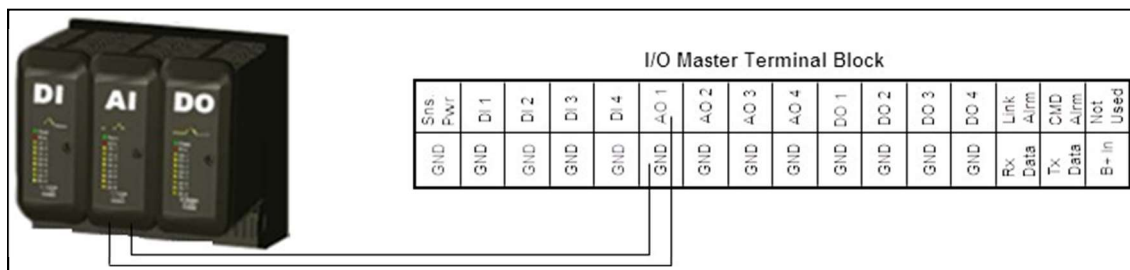
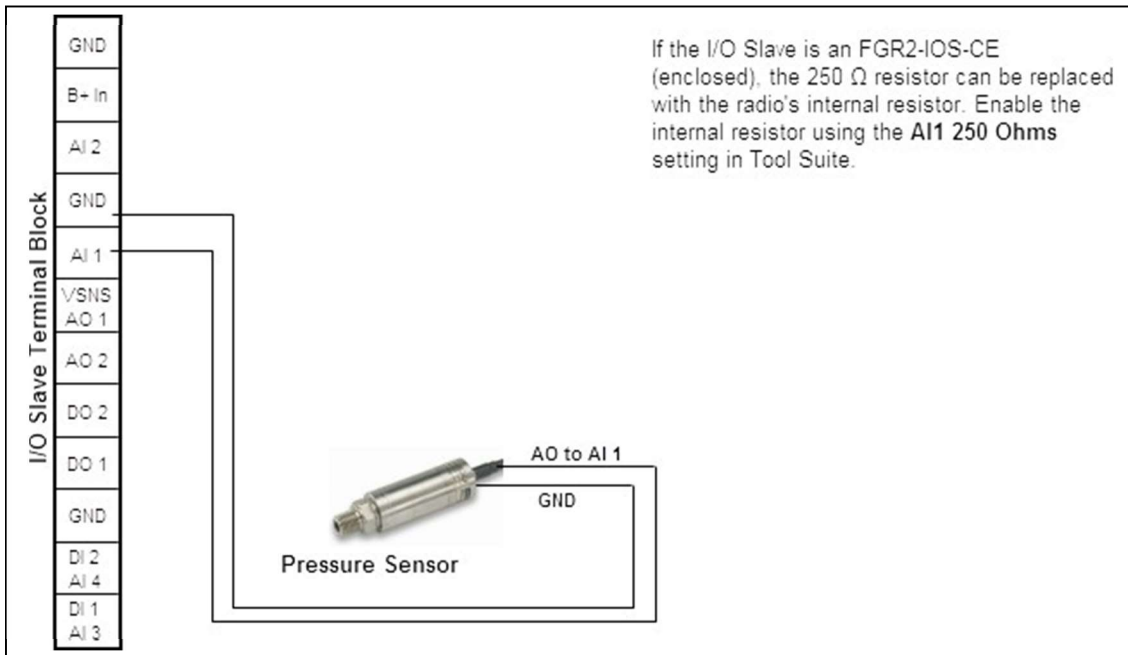

Figure 19: Wire the AO1 to RTU Analog Input for the tubing sensor.

### 5.7.2 I/O Slave to the Well Head

Wire the terminal ports on the I/O Slave to the tubing sensor. Wire the sensor to ground.



**Figure 20: Wire the terminal ports on the I/O Slave to the tubing sensor. Wire the sensor to ground.**

### 5.7.3 Terminal Port Mappings in Tool Suite

1. Verify both the I/O Master and the I/O Slave are configured as described in the other sections within this manual and that the I/O Master can connect to the I/O Slave.
2. Connect to the I/O Master and select the I/O Settings tab. Map the Analog Out 1 to Slave AI1 for the tubing sensor

**Note:** The I/O Slave is listed by serial number. As there is only one I/O Slave in the network in this example, only one Slave is listed in the port selection fields. If there were additional I/O Slaves in the network, each Slave to which the I/O Master is connected displays in the list.

---

## 6. Viewing Radio Statistics

When reading a radio, the system shows data transmission statistics the radio has gathered during the most recent session.

- This information is valuable to know the signal strength and noise levels of the link.
- Statistics are gathered during each data link and are reset when the next link begins.
- View additional data transmission characteristics in the Network Diagnostics application.

**Note:** For information about running network diagnostics using [Tool Suite](#), see the [Tool Suite User Manual](#).

### 6.1 Viewing the Radio Statistics in [Tool Suite](#)

1. In the [Tool Suite](#) Configuration application, click **Read Radio**.
2. Click the **Device Information** tab.
3. Review the radio characteristics.

**Note:** View the same statistics using the [Tool Suite Setup Terminal](#) option.

### 6.2 Viewing the Radio Transmission Characteristics in the Terminal Interface

1. On the **Setup** main menu, click **(4) Show Radio Statistics**.
2. Review the radio characteristics.

## 6.3 Antenna Reflected Power

This is a measurement of the transmitted power that is reflected back into the radio from mismatched antennas or cables, or loose connections between the radio and antenna.

- A reading of:
  - 0 to 5 is good.
  - 5 to 20 is marginal.
  - 20 or higher indicates that the connections should be inspected for loose connections and cable quality.
  - 30 or higher indicates a definite problem in the system.

The most likely reason for a higher **Antenna Reflected Power** reading is a cable issue between the radio and the antenna: loose connections, cable kinks, breaks in cable shielding, moisture in the fittings or connections, etc.

Less commonly, a high **Antenna Reflected Power** reading can indicate a hardware problem with the radio itself, such as a damaged RF connector. Lastly, a high reading may indicate a problem with the antenna itself, although antenna problems are the least likely indicator.

## 6.4 Master-Slave Distance

The physical distance between the slave radio and the master radio in the network.



**Tip:** This distance is most accurate at a distance greater than 2.5 miles.

## 6.5 Noise Level

The **Noise Level** indicates the level of background noise and interference at this radio and at each of the Repeaters in the link. The number is an average of the noise levels measured at each frequency in the radio's frequency hop table.

- Noise levels significantly higher than this are an indication of a high level of interference that may degrade the performance of the link.



**Tip:** The individual measurement values at each frequency hop channel are shown in the frequency table.  
If viewing statistics in the terminal interface, press <Enter> when the **Radio Statistics** menu appears to view the frequency table.

**FreeWave Recommends:** Ideally, noise levels should be below -120 dBm. The difference between the average signal level and average noise level should be 26 or more.

## 6. Viewing Radio Statistics

- High noise levels can often be mitigated with band pass filters, antenna placement or antenna polarization.

### 6.6 Number of Disconnects

Anytime the link between the Master and the Slave is broken and the radios lose Carrier Detect.

- The value indicates the total number of disconnects that have occurred from the time the radio is powered on until the radio is put into **Setup** mode.
- Under ideal operating conditions, the number of disconnects should be **0**.
- One or more disconnects may indicate a weak link, the presence of severe interference problems or loss of power to any of the radios in the link.

**Note:** In **Tool Suite**, the disconnect information is available in the **Summary View** in the **Network Diagnostics** application.

### 6.7 Radio Temperature

The **Radio Temperature** value is the current operating temperature of the radio in degrees Celsius.

**FreeWave Recommends:** For proper operation, a FreeWave radio must be in the temperature range of -40° to +75° C.  
Some of the radios are only tested to 0° C.

**Note:** See the radio specifications in this document for details.

### 6.8 Rate %

The **Rate %** measures the percentage of data packets that were successfully transmitted from the Master to the Slave on the first attempt.

- A value of **75** or higher indicates a robust link that provides very good performance even at high data transmission rates.
- A value of **15** or lower indicates a weak or marginal link that provides lower data throughput.
- A **Rate %** of **100%** provides approximately:
  - 100 Kbaud of bandwidth with an **RF Data Rate** setting of **3**.
  - 150 Kbaud of bandwidth with an **RF Data Rate** of **2**.
- These numbers are reduced approximately 50% if one or more Repeaters are in the network.



## 6.9 Signal Level

The **Signal Level** indicates the level of received signal at this radio and at each of the Repeaters in the link.

- For each of these, the signal source is the radio that transmits to it.
- The number is an average of the received signal levels measured at each frequency in the radio's frequency hop table.



**Tip:** The individual measurement values at each frequency hop channel are shown in the frequency table. If you are viewing statistics in the terminal interface, press Enter when the Radio Statistics menu displays to view the frequency table.

- For a reliable link, the margin should be at least 26 dB.
- Low average signal levels can often be corrected with higher gain antennas, better antenna placement and/or additional Repeaters.

## 6.10 Transmit Current

The **Transmit Current** measures the current draw of the transmitter in milliamps (mA).

---

## 7. Modbus Register Map

This section provides a map and details for each entity in the Modbus register for the Modbus I/O devices. The register map is grouped by the register type:

- Holding Coils (Read/Write) - Read/Write outputs or coils. A 0xxxx reference address is used to drive output data to a digital output channel.
- Discrete Inputs (Read Only) - The corresponding digital input channel controls the ON/OFF status of a 1xxxx reference address.
- Input Registers (Read-Only) - A 3xxxx reference register contains a 16-bit number received from an external source, for example, an analog signal.
- Holding Registers (Read/Write) - A 4xxxx reference register stores 16-bits of binary or decimal numerical data, or sends the data from the CPU to an output channel.

## 7.1 Modbus I/O Slave Register Map

This table provides a register map for the Modbus I/O Slaves. Each entity is described in detail in the sections following the table.

**Note:** The radio treats requested register addresses below 00256 as implicitly referencing higher registers according to the command code issued. For example, a command to “Read Holding Register 00003” returns the contents of register 40003, as the Holding Registers all reside at 40000 and above.

Similarly, a command to “Read Discrete Input 00002” returns the state of address 10002. A request to “Read Coil 00002” returns the state of address 00002, as the coils actually are resident at addresses below 256.

Color Key					
Read Only, RO			Read/Write, RW		Non-Volatile on PWR cycle, 10,000-write lifetime limit
Type	ADDRESS		ENTITY	BITS	NOTES
	PROTOCOL	PLC			All addresses described are "PLC" numbers
<b>Coils, read with command code 01, write with command code 05.</b>					
"COIL"	0	1	DO1	1	On Read, returns actual state if ~= Command; Power-up Default = OFF
"COIL"	1	2	DO2	1	On Read, returns actual state if ~= Command; Power-up Default = OFF
"COIL"	2	3	SENSOR PWR	1	On Read, returns actual state if ~= Command
"COIL"	3	4	SENSOR DEFAULT	1	Default = OFF
"COIL"	4	5	DO1 FAULT	1	Auto-Clears fault if successful retry
"COIL"	5	6	DO2 FAULT	1	Auto-Clears fault if successful retry
"COIL"	6	7	SENSOR PWR FAULT	1	Auto-Clears fault if successful retry

7. Modbus Register Map

Color Key					
Read Only, RO			Read/Write, RW		Non-Volatile on PWR cycle, 10,000-write lifetime limit
Type	ADDRESS		ENTITY	BITS	NOTES
	PROTOCOL	PLC			All addresses described are "PLC" numbers
"COIL"	7	8	COMM FAIL FAULT LATCH	1	DOx have defaulted, clear by user
"COIL"	8	9	CLEAR COUNTER1 ON READ	1	Default OFF
"COIL"	9	10	CLEAR COUNTER2 ON READ	1	Default OFF
"COIL"	10	11	COUNTER1INC ON 0-1 EDGE	1	Default OFF; Increment on 1-0 Edge
"COIL"	11	12	COUNTER2INC ON 0-1 EDGE	1	Default OFF; Increment on 1-0 Edge
"COIL"	12	13	DO1 LEAVE UNCHANGED	1	Default ON, Overrides DO1 Default
"COIL"	13	14	DO2 LEAVE UNCHANGED	1	Default ON, Overrides DO2 Default
"COIL"	14	15	DO1 DEFAULT STATE	1	Default OFF
"COIL"	15	16	DO2 DEFAULT STATE	1	Default OFF
"COIL"	16	17	COUNTER1INC LATCH	1	ON at inc; OFF by user
"COIL"	17	18	COUNTER2INC LATCH	1	ON at inc; OFF by user
"COIL"	18	19	COUNTER1 CLEAR	1	Default OFF, pulsed so Read = always OFF
"COIL"	19	20	COUNTER2 CLEAR	1	Default OFF, pulsed so Read = always OFF
"COIL"	20	21	AI1 OFFSET CLIP AT 0	1	Default ON
"COIL"	21	22	AI2 OFFSET CLIP AT 0	1	Default ON
"COIL"	22	23	Reserved	1	

"COIL"	23	24	Ignore Broadcasts	1	Turn OFF to obey broadcasts (ID=0), defaults ON
"COIL"	24	25	DI1 PULLUP	1	Default ON, OFF = PULLDOWN

7. Modbus Register Map

Color Key					
Read Only, RO			Read/Write, RW		Non-Volatile on PWR cycle, 10,000-write lifetime limit
Type	ADDRESS		ENTITY	BITS	NOTES
	PROTOCOL	PLC			All addresses described are "PLC" numbers
"COIL"	25	26	DI2 PULLUP	1	Default ON, OFF = PULLDOWN
"COIL"	26	27	DO's BI-STABLE	1	Default ON, OFF = Monostable (1-shot)
"COIL"	27	28	AO1/VSNS LEAVE UNCHANGED	1	Default ON, Overrides AO1/VSNS Default Cmd
"COIL"	28	29	AO2 LEAVE UNCHANGED	1	Default ON, Overrides AO2 Default Command
"COIL"	29	30	DEBOUNCE COUNTERS IN	1	Default ON; OFF for High Speed Counting
"COIL"	30	31	FILTER COUNTERS IN	1	Default ON; OFF for High Speed Counting
"COIL"	31	32	RESET RADIO	1	Always Reads OFF; Write ON for Reset
"COIL"	32	33	FAST AI(DI1)	1	Default ON = Samples, OFF=Filtered Average
"COIL"	33	34	FAST AI(DI2)	1	Default ON = Samples, OFF=Filtered Average
"COIL"	34	35	DI1 PULLUP ACTIVE	1	Default ON; OFF Overrides DI1PULLUP
"COIL"	35	36	DI2 PULLUP ACTIVE	1	Default ON; OFF Overrides DI2PULLUP
"COIL"	36	37	AI1 250 OHM PD ACTIVE	1	Default OFF, Enclosure Model Only
"COIL"	37	38	AI2 250 OHM PD ACTIVE	1	Default OFF, Enclosure Model Only
"COIL"	38	39	DI1 125 OHM PD ACTIVE	1	Default OFF, Enclosure Model Only
"COIL"	39	40	DI2 125 OHM PD ACTIVE	1	Default OFF, Enclosure Model Only

Color Key					
Read Only, RO			Read/Write, RW		Non-Volatile on PWR cycle, 10,000-write lifetime limit
Type	ADDRESS		ENTITY	BITS	NOTES
	PROTOCOL	PLC			All addresses described are "PLC" numbers
"COIL"	40	41	Reserved	1	
"COIL"	41	42	Reserved	1	
"COIL"	42	43	Reserved	1	
"COIL"	43	44	Reserved	1	
"COIL"	44	45	AI1 250 OHM PD FAULT	1	Enc. Model Only; Auto-Clears if succ. retry
"COIL"	45	46	AI2 250 OHM PD FAULT	1	Enc. Model Only; Auto-Clears if succ. retry
"COIL"	46	47	DI1 125 OHM PD FAULT	1	Enc. Model Only; Auto-Clears if succ. retry
"COIL"	47	48	DI2 125 OHM PD FAULT	1	Enc. Model Only; Auto-Clears if succ. retry
<b>Discrete Inputs, read with command code 02.</b>					
DISCRETE IN	10000	10001	DI1	1	Real-Time state of DI1; "1" = DI1 > 1.75V
DISCRETE IN	10001	10002	DI2	1	Real-Time state of DI2; "1" = DI2 > 1.75V
DISCRETE IN	10002	10003	D1 of AI1	1	Compare of AI1: "1" = AI1 > 1.65V
DISCRETE IN	10003	10004	DI OF AI2	1	Compare of AI2: "1" = AI2 > 1.65V
DISCRETE IN	10004	10005	DTR	1	Real-Time state of IODTR line on J3
<b>Input Registers, read with command code 04.</b>					

7. Modbus Register Map

Color Key					
Read Only, RO			Read/Write, RW		Non-Volatile on PWR cycle, 10,000-write lifetime limit
Type	ADDRESS		ENTITY	BITS	NOTES
	PROTOCOL	PLC			All addresses described are "PLC" numbers
INPUT REG	30000	30001	AI1 MSW	16	Upper 16-bits; msb=5V, lsb=152.587uV
INPUT REG	30001	30002	A1 LSW	16	Lower bits, lsb=2.3283nV
INPUT REG	30002	30003	AI2 MSW	16	Upper 16-bits; msb=5V, lsb=152.587uV
INPUT REG	30003	30004	A2 LSW	16	Lower bits, lsb=2.3283nV
INPUT REG	30004	30005	DI1 COUNTER MSW	16	Upper 16-bits of 32-bit counter
INPUT REG	30005	30006	DI1 COUNTER LSW	16	Lower 16-bits of 32-bit counter
INPUT REG	30006	30007	DI2 COUNTER MSW	16	Upper 16-bits of 32-bit counter
INPUT REG	30007	30008	DI2 COUNTER LSW	16	Lower 16-bits of 32-bit counter
INPUT REG	30008	30009	Vbatt	16	Supply Voltage; 0-33.164V, lsb=32.62mV
INPUT REG	30009	30010	degC	16	Signed degC temperature of radio PCB
INPUT	30010	30011	ALL DI'S	16	10016:10001, unused bits = 0's



Color Key					
Read Only, RO		Read/Write, RW		Non-Volatile on PWR cycle, 10,000-write lifetime limit	
Type	ADDRESS		ENTITY	BITS	NOTES
	PROTOCOL	PLC			All addresses described are "PLC" numbers
REG					
INPUT REG	30011	30012	ALL COILS 16:1	16	PLC Addresses 16:1, but Read-Only
INPUT REG	30012	30013	ALL COILS 32:17	16	PLC Addresses 32:17, but Read-Only
INPUT REG	30013	30014	AI1 MSW Offset Result	16	AI1 MSW - AI1 USER OFFSET
INPUT REG	30014	30015	AI2 MSW Offset Result	16	AI2 MSW - AI2 USER OFFSET
INPUT REG	30015	30016	AI(DI1)	16	0-3.5Vin; Isb=53.406uV
INPUT REG	30016	30017	AI(DI2)	16	0-3.5Vin; Isb=53.406uV
INPUT REG	30017	30018	AI1	32FP	IEEEE754 Short Float in unscaled Volts
INPUT REG	30019	30020	AI2	32FP	IEEEE754 Short Float in unscaled Volts
INPUT REG	30021	30022	AI(DI1)	32FP	IEEEE754 Short Float in unscaled Volts
INPUT REG	30023	30024	AI(DI2)	32FP	IEEEE754 Short Float in unscaled Volts

7. Modbus Register Map

Color Key					
Read Only, RO			Read/Write, RW		Non-Volatile on PWR cycle, 10,000-write lifetime limit
Type	ADDRESS		ENTITY	BITS	NOTES
	PROTOCOL	PLC			All addresses described are "PLC" numbers
INPUT REG	30025	30026	Vbatt	32FP	IEEE754 Short Float in unscaled Volts
INPUT REG	30027	30028	degC	32FP	IEEE754 Short Float in unscaled Celsius
INPUT REG	30029	30030	DO1 CURRENT	16	lsb=534 uA, Res=34 mA; Not Accurate in Fault
INPUT REG	30030	30031	DO2 CURRENT	16	lsb=534 uA, Res=34 mA; Not Accurate in Fault
INPUT REG	30031	30032	Reserved1	16	
INPUT REG	30032	30033	Reserved2	16	
INPUT REG	30033	30034	ALL COILS 48:33	16	PLC Addresses 48:33, but Read-Only
INPUT REG	30034	30035	Reserved		
INPUT REG	30035	30036	Reserved		
INPUT REG	30036	30037	Reserved		
INPUT	30037	30038	Discrete In 16:1	16	PLC Addr 16:1, Read-Only, MSB=16,

Color Key					
Read Only, RO			Read/Write, RW		Non-Volatile on PWR cycle, 10,000-write lifetime limit
Type	ADDRESS		ENTITY	BITS	NOTES
	PROTOCOL	PLC			All addresses described are "PLC" numbers
REG					LSB=1
INPUT REG	30038	30039	Reserved		
INPUT REG	30039	30040	Reserved		
INPUT REG	30040	30041	Reserved		
INPUT REG	30041	30042	Reserved		
INPUT REG	30042	30043	Reserved		
<b>Holding Registers, read with command code 03.</b>					
HOLDING REG	40000	40001	ALL COILS 16:1	16	PLC Addresses 16:1
HOLDING REG	40001	40002	ALL COILS 32:17	16	PLC Addresses 32:17
HOLDING REG	40002	40003	DO's DEFAULT DELAY	16	.28 sec units of Retry Timeout to DO Defaults
HOLDING REG	40003	40004	AI1 USER OFFSET	16	Value to subtract from 30001 for 30014
HOLDING REG	40004	40005	AI2 USER OFFSET	16	Value to subtract from 30002 for 30015

7. Modbus Register Map

Color Key					
Read Only, RO			Read/Write, RW		Non-Volatile on PWR cycle, 10,000-write lifetime limit
Type	ADDRESS		ENTITY	BITS	NOTES
	PROTOCOL	PLC			All addresses described are "PLC" numbers
REG					
HOLDING REG	40005	40006	DO MONOSTABLE TIME	16	Duration of DO ON, if 27 OFF, ~.15sec/count, range 0-255
HOLDING REG	40006	40007	AO1 Command	16	0-20mA: lsb=335.693nA
HOLDING REG	40007	40008	AO2 Command	16	0-20mA: lsb=335.693nA
HOLDING REG	40008	40009	AO1/VSNS Default Command	16	0-20mA: lsb=335.693nA
HOLDING REG	40009	40010	AO2 Default Command	16	0-20mA: lsb=335.693nA
HOLDING REG	40010	40011	AO1 Custom Offset	16	Added to 40007 lsb=335.693nA
HOLDING REG	40011	40012	AO2 Custom Offset	16	Added to 40008 lsb=335.693nA
HOLDING REG			Reserved		
HOLDING REG			Reserved		
HOLDING REG			Reserved		

Color Key					
Read Only, RO			Read/Write, RW	Non-Volatile on PWR cycle, 10,000-write lifetime limit	
Type	ADDRESS		ENTITY	BITS	NOTES
	PROTOCOL	PLC			All addresses described are "PLC" numbers
HOLDING REG			Reserved		
HOLDING REG	40033	40034	ALL COILS 48:33	16	PLC Addresses 48:33, but Read-Only
HOLDING REG	40034	40035	Reserved		reserved for Coils 64:49
HOLDING REG	40035	40036	Reserved		reserved for Coils 80:65
HOLDING REG	40036	40037	Reserved		reserved for Coils 96:81
HOLDING REG	40037	40038	Discrete In 16:1	16	PLC Addrs 16:1, Read-Only, MSB=16, LSB=1
HOLDING REG	40038	40039	Reserved		
HOLDING REG	40039	40040	Reserved		
HOLDING REG	40040	40041	Reserved		
HOLDING REG	40041	40042	Reserved		
HOLDING	40042	40043	Reserved		reserved for Discrete In 96:81

7. Modbus Register Map

Color Key					
Read Only, RO		Read/Write, RW		Non-Volatile on PWR cycle, 10,000-write lifetime limit	
Type	ADDRESS		ENTITY	BITS	NOTES
	PROTOCOL	PLC			All addresses described are "PLC" numbers
REG					
HOLDING REG	42000	42001	DI1	1	Real-Time state of DI1; "1" = DI1 > 1.75V
HOLDING REG	42001	42002	DI2	1	Real-Time state of DI2; "1" = DI2 > 1.75V
HOLDING REG	42002	42003	DI of AI1	1	Compare of AI1: "1" = AI1 > 1.65V
HOLDING REG	42003	42004	DI of AI2	1	Compare of AI2: "1" = AI2 > 1.65V
HOLDING REG	42004	42005	DTR	1	Real-Time state of IODTR line on J3

## 7.2 Coil Descriptions

Read these Coils with command code 01 and write with command code 05.

### 7.2.1 1 DO1; DISCRETE OUTPUT #1

- Emulates a contact closure to GND using a solid-state device.
- Rated current is 2.0 Amps maximum; protection algorithms shut OFF the DO at about 2.25 Amps.
- See [5 DO1 FAULT \(on page 111\)](#) for Fault sensing and coils 13, 15, and register 40003 for default settings.
- [27 DO's BI-STABLE \(on page 114\)](#) and Register 40006 allow automatic shut OFF of the DO after an interval.

### 7.2.2 2 DO2; DISCRETE OUTPUT #2

Similar operation to Coil 1.

### 7.2.3 3 SENSOR POWER

- Radio power-on default controlled by Coil 4.
- See Coil 7 for Fault sensing.
- The I/O terminal is now shared with Analog Output AO1.
- Activation of this coil overrides any setting of AO1.

### 7.2.4 4 SENSOR POWER-ON DEFAULT

Factory pre-set to **ON**.

### 7.2.5 5 DO1 FAULT

- DO1 Current is sensed and turned **OFF** if > 2.25 A nominal, resulting in an **ON** condition of this synthetic “coil”.
- Radio periodically turns DO1 back **ON** and checks for persistence of Fault.
- If the fault condition ends, this coil automatically reverts to **OFF**.

### 7.2.6 6 DO2 FAULT

Similar operation to Coil 5.

### 7.2.7 7 SENSOR POWER FAULT

- Similar operation to Coils 5 and 6, except the Fault threshold is >50 mA.
- An algorithm allows the Fault threshold to be exceeded for several milliseconds to allow charging of the external sensor bypass capacitors.
- Sensors having large bypass capacitance may nevertheless force this Fault and not be usable with the Sensor Power output.
- Such devices may be low-side switched with a DO or permanently powered by B+ IN.
- It is possible to achieve an extra pseudo-DI function by powering a resistor sized to draw approximately 100 mA from Sensor Power connected to a contact closure whose other side is GND. Closure causes a “1” on Read of this coil.
- Since the re-try duty cycle of the 100 mA current is low, only about 1 mA of extra average supply current results.
- Any powered sensors present would need to be powered by direct connection to B+ IN.

### 7.2.8 8 COMM FAIL FAULT LATCH

- In case of communication failure, DOs can be set up to go to default states under control of Coils 13 to 16.
- This coil serves to inform (after communication is restored) that the link was lost long enough to activate the Defaults.
- This coil remains **ON** until turned **OFF** by Modbus command.

### 7.2.9 9 CLEAR COUNTER 1 ON READ

- If **ON**, this coil causes the DI1 counter to be cleared automatically when Read, preventing loss of counts occurring between a Read and subsequent Clear (see Coil 19).
- This coil only functions if the Read is of both Registers 30005 and 30006.
- Factory default setting is **OFF**, so that **DI1 Counter** accumulates up to the maximum value of 4,294,967,295.

### 7.2.10 10 CLEAR COUNTER 2 ON READ

Similar operation to Coil 9.

### 7.2.11 11 COUNTER1 INC ON 0-1 EDGE

- Factory default setting is **OFF**, so that falling edges of DI1 cause the counter to increment.
- Change of this setting by Modbus command may cause a false increment.



### 7.2.12 12 COUNTER2 INC ON 0-1 EDGE

Similar to Coil 11.

### 7.2.13 13 DO1 LEAVE UNCHANGED

- Factory default setting is **ON**.
- You may not want the radio to automatically enter defined default states after communication loss.
- This coil takes precedence over the default state setting of Coil 15.

### 7.2.14 14 DO2 LEAVE UNCHANGED

Similar to Coil 13.

### 7.2.15 15 DO1 DEFAULT STATE

- Factory default setting is **OFF**.
- If Coil 13 is **OFF** and communication is lost longer than the timeout of Register 40003, DO1 goes to the state of this coil.

### 7.2.16 16 DO2 DEFAULT STATE

Similar to Coil 15.

### 7.2.17 17 COUNTER1 INC LATCH

- Power-on state is **OFF**.
- Latch is set **ON** when an increment event occurs on DI1 and can only be cleared to **OFF** using a Modbus command.
- This is useful for single event detection, such as plunger arrival.

### 7.2.18 18 COUNTER2 INC LATCH

Similar to Coil 17

### 7.2.19 19 COUNTER1 CLEAR

- Forced reset to zero of **DI1 Counter**.
- Setting this coil to **ON** clears the counter and this coil, so that a Read of this coil is always **OFF**.

### 7.2.20 20 COUNTER2 CLEAR

Similar to Coil 19.

### 7.2.21 21 AI1 OFFSET CLIP AT 0

- ON - Unsigned Offset calculation ( $30014 = 30001 - 40004$ ) forced to zero in case:  $40004 > 30001$ .
- OFF: Unsigned Offset calculation ( $30014 = 30001 - 40004$ ) allowed to wrap in case:  $40004 > 30001$ .

**Example:** If  $40004 = 30001 + 1$ ,  $30014 = 65,535$ .

### 7.2.22 22 AI2 OFFSET CLIP AT 0

Similar to Coil 21.

### 7.2.23 25 DI1 PULLUP

---

**Important!:** When toggling this coil between **ON** and **OFF**, the device automatically reboots.

---

- Factory default setting is **ON**.
- A 10KOhm internal resistor attached to the input is connected to the 3.3 V logic supply to provide a pullup for closed-contact-to-GND sensors.
- Turning this coil **OFF** connects the resistor as a pulldown to GND for use with closed- contact-to-voltage sensors.

### 7.2.24 26 DI2 PULLUP

Similar to Coil 25.

### 7.2.25 27 DO's BI-STABLE

- Factory default setting is **ON**.
- States of DO1 and DO2 are persistent unless changed by Modbus command or communication loss defaults.
- If Coil 27 is reset to **OFF** (mono-stable), a DO **ON** state will timeout after an interval set in Register 40006.
- In case a communication loss default turns **ON** the DO, a single **ON** interval occurs even if the link repeatedly restores and fails.
- Clearing the **Coil 8: Comm Fail Fault Latch** re-arms for communication loss default events to turn **ON** the DO.
- Each actual Modbus **ON** command to a DO results in a new **ON** interval.

- The automatic timeout mode is useful if the DO is connected to a device which is not rated for continuous **ON**, so that link or SCADA outages do not damage it.
- Modbus traffic may be reduced, as the need to command a DO back **OFF** may be eliminated.

### 7.2.26 28 AO1/VSNS LEAVE UNCHANGED

- Factory default setting is **ON**.
- **ON** causes the AO to stay at its current state when the radio goes to default conditions.
- This overrides the default state in Holding Register 40009.

### 7.2.27 29 AO2 LEAVE UNCHANGED

- Factory default setting is **ON**.
- **ON** causes the AO to stay at its current state when the radio goes to default conditions.
- This overrides the default state in Holding Register 40010.

### 7.2.28 30 DEBOUNCE COUNTERS

- Factory default setting is **ON**.
- See the **Debounced** option in [Counting Mode \(on page 52\)](#).

### 7.2.29 31 FILTER COUNTERS

- Factory default setting is **ON**.
- See the **Filtered** option in [Counting Mode \(on page 52\)](#).

### 7.2.30 32 RESET RADIO

- Write **ON** to reset the radio.
- This is mostly for Modbus parsing in the menus, used to reset the radio to get back to operation mode.

### 7.2.31 33, 34 FAST AI(DI1)/FAST AI(DI2)

- **ON** is raw fast, no filtering, AI(DI).
- **OFF** is filtered average.

### 7.2.32 35, 36 DI1/DI2 PULLUP ACTIVE

- **ON** leaves DI pull up enabled, which is the default condition.
- **OFF** turns off DI pull up.

### **7.2.33 37,38 AI1 AI2 250 OHM PD ACTIVE**

- **ON** turns on 250 ohm termination resistor for AI, turning 4-20 mA signal into 1-5V for sampling.
- Only applicable to the enclosed radio models.

### **7.2.34 39, 40 DI1 125 OHM PD ACTIVE**

- **ON** turns on 125 ohm termination resistor for DI.
- Only applicable to the enclosed radio models.

### **7.2.35 45, 46 AI1/AI2 250 OHM PD FAULT**

- **ON** means current through 250 ohm termination resistor for AI was too high, termination resistor is disabled.
- This coil clears when the termination resistor is retried and is not in a fault condition.

### **7.2.36 47, 48 DI1/DI2 125 OHM PD FAULT**

- **ON** means current through 125 ohm termination resistor for AI 3 and 4 was too high, termination resistor is disabled.
- This coil clears when the termination resistor is retried and is not in a fault condition.

## **7.3 Discrete Input Descriptions**

Read these Discrete Inputs with command code 02.

### **7.3.1 10003 DI OF AI1**

The present state of DI1. Logic threshold is 1.15 to 2.15 V.

### **7.3.2 10003 DI OF AI1**

Similar to Register 10001.

### **7.3.3 10003 DI OF AI1**

- The most recent conversion of AI1 compared to a threshold of 1.65 V exactly.
- This comparison is made at 330 msec intervals and no counting or latching functions are available.
- Useful for slow devices such as float switches.

- The AIs present a 136 KOhm resistance to GND, so a 10 K pullup resistor is required between the analog channel and power supply (B+) when using a contact to GND or open collector as the source.

### 7.3.4 10004 DI OF AI2

Similar to Register 10003.

### 7.3.5 10005 DI of IODTR

- Pin 3 of the J3 10-pin connector can be used as an auxiliary DI.
- The pin presents a 3 KOhm to 7 KOhm resistance to GND and a threshold voltage of up to 2.4 V.
- For use with a contact to GND or open collector, a pullup resistor must be supplied that is able to pull the input above 2.4 V.

**Example:** A recommended resistor for a 12 V pullup source would be 8.2 KOhm or less.

## 7.4 Holding Register Descriptions

Read these registers with command code 03.

### 7.4.1 40001 ALL COILS 16:1 READ ONLY

Holding Register combining Coils 16:1 in a single register.

### 7.4.2 40002 ALL COILS 32:17 READ ONLY

Holding Register combining Coils 29:17 in a single register.

### 7.4.3 40003 DO's DEFAULT DELAY

The duration in units of 1/3 second that the radio DOs will hold their current values while searching for the network before invoking the Default settings of Coils 13-16.

### 7.4.4 40004 AI1 USER OFFSET

- An unsigned integer to be subtracted from the AI1 MSW at Register 30001, with the result placed in Register 30014.
- Useful for translating offset sensors such as 1-5 V or 4-20 mA types so that their minimum output Reads as \$0000 in Register 30014.

### 7.4.5 40005 AI2 USER OFFSET

Similar to Holding Register 40004.

### 7.4.6 40006 DO MONOSTABLE TIME

- If Coil 27 is **OFF**, this register sets the time interval before a DO in the **ON** state is automatically shut **OFF**.
- Range is 0-255 in units of approximately 0.15 second.

### 7.4.7 40007, 40008 AO1/AO2 Command

- Analog value to be output on AO. Least significant bit corresponds to 335.693 nA.
- Nominal range is from 0-22 mA.

### 7.4.8 40009, 40010 AO1/AO2 Default Command

AO command value in default conditions.

### 7.4.9 40011, 40012 AO1/AO2 Custom Offset

AO custom offset. Added to AO command before output.

### 7.4.10 42001-42005 Discrete inputs mapped to individual holding registers

- Discrete inputs mapped into individual input registers.
- If Discrete Input 10001 is set to **ON**, then Holding Register 42001 is equal **1**.
- If Discrete Input 10001 is equal to **OFF**, then Holding Register 42001 is equal to **0**.
- This is NOT recommended, use Holding Register 40038 or Discrete Inputs.

## 7.5 Input Register Descriptions

Read these registers with command code 04.

### 7.5.1 30001 AI2 LSW

- The Most Significant Word of the AI1 conversion.
- One least-significant-bit (lsb) = 152.587 uV.
- Although full scale would be 10 V, the hardware limits the maximum to 5.625 V.
- Most users only require this MSW.

### 7.5.2 30002 AI2 LSW

- If the maximum possible resolution is required, the final 5 bits of the AI1 conversion are here, left-justified.

- This is so that the MSW, LSW register pair can be regarded as a 32-bit unsigned integer with  $10\text{ V} = \$\text{FFFFFFFF}$ .

### 7.5.3 30003 AI2 LSW

Similar to Register 30001.

### 7.5.4 30004 AI2 LSW

Similar to Register 30002.

### 7.5.5 30005 DI1 COUNTER MSW

- The upper 16 bits of a 32 bit DI1 counter (unsigned) formed by registers 30005, 30006.
- The Counter is controlled by Coils 9, 11, 19.
- Maximum count rate is dependent on **Max** and **Min Packet Sizes**.
- Sizes 2, 2 allow counting as low as 20 msec per phase (both “1” and “0”), while sizes 9, 9 allow only down to 50 msec per phase.

### 7.5.6 30006 DI1 COUNTER LSW

- The lower 16 bits of the 30005, 30006 Counter.
- This LSW is used often but, if the Clear-On-Read function of Coil 9 is needed, both registers must be Read in a single command.

### 7.5.7 30007 DI2 COUNTER MSW

Similar to Register 30005.

### 7.5.8 30008 DI2 COUNTER LSW

Similar to Register 30006.

### 7.5.9 30009 VBATT

- The supply voltage to the radio as an unsigned integer in units of 32.62 mV per lsb.
- Useful for remote monitoring of battery charge.

### 7.5.10 30009 VBATT

The temperature of the radio PCB as a signed integer with units of 1 degree Celsius per lsb.

### 7.5.11 30011 ALL DIs

For convenience, all the DIs are combined in a single word, with DI1 as lsb and unused bits Read as 0.

### 7.5.12 30012 ALL COILS 16:1

For convenience, Coils 16:1 are combined in a single word, with Coil 1 as lsb.

### 7.5.13 30013 ALL COILS 32:17

For convenience, Coils 32:17 are combined in a single word, with Coil 17 as lsb. Unused bits are Read as 0.

### 7.5.14 30014 AI1 MSW Offset Result

- Some Modbus controllers lack a convenient means of adjusting Modbus AI readings for offset.

**Example:** A 1-5 V pressure transmitter would define 0 PSI as a 1.00 V output, for which the AI1 conversion MSW would be 6553.

- For convenience, enter an unsigned integer (such as 6553) in Register 40004 which will be subtracted from the AI1 MSW of Register 30001 and the unsigned result placed here.
- No provision for multiplicative scaling is made and no corrected LSW is available.
- Negative results may be forced to \$0000 according to Coil 21, or allowed to wrap to 65,536.

### 7.5.15 30015 AI2 MSW Offset Result

Similar to Register 30014.

### 7.5.16 30016 AI(DI1)

- An analog voltage applied to the DI1 terminal is measured and can be read at this register.
- Range of the input is 0-3.5 V with scale of 53.406 uV/lb.
- The converter used has 10-bit resolution.
- If using a wiring setup that halves the voltage from the 1-5 V sensor, the digitized value of the DI voltage will represent the actual (halved) voltage at the DI.
- The scaling factor of 53.406 uV/lb keeps this halved voltage.
- To obtain the voltage level read by the 1-5 V sensor before it was halved, multiply the voltage read from Register 30016 by a factor of two.
- A simple digital lowpass filter is applied to reduce the effect of random noise and has a packet-size dependent time constant of about 0.5 to 2 seconds.



- The filters' effectiveness against coherent signals, such as power line interference, varies with packet size in a complicated manner.
- Some combinations of packet size, interfering frequency and accuracy needed require the interfering signal be mitigated with external filtration or shielding.

### **7.5.17 30017 AI(DI1)**

Similar to Register 30016.

### **7.5.18 30018, 30019 AI1 SHORT FLOAT**

- This register pair, which should be read together, forms an IEEE754 standard Short (32 bit) Floating Point number which is the value in register 30001 AI1 MSW converted to an un-scaled voltage.
- Neither register 30002 AI1 LSW nor 40004 AI1 User Offset contribute to this value.

### **7.5.19 30020, 30021 AI1 SHORT FLOAT**

Similar to Register 30018, 30019.

### **7.5.20 30022, 30023 AI(DI1) SHORT FLOAT**

Similar to Register 30018, 30019.

### **7.5.21 30024, 30025 AI(DI2) SHORT FLOAT**

Similar to Register 30018, 30019.

### **7.5.22 30026, 30027 VBATT SHORT FLOAT**

Similar to Register 30018, 30019.

### **7.5.23 30028, 30029 DEGC SHORT FLOAT**

Similar to Register 30018, 30019. Units are degrees Celsius.

### **7.5.24 30030 DO1/DO2 CURRENT**

Current measurement of DO, least significant bit is 916 uA, not accurate during protection as circuit is open, not conducting current.

### **7.5.25 30034 ALL COILS 33:48**

Coils 33:48 mapped into an input register, similar to Register 30012,30013.

### **7.5.26 30038 DISCRETE IN 1:16**

Discrete inputs 1:16 mapped into an input register. Most significant bit is discrete input 16, least significant bit is input 1.

## 8. Specifications

---

These are the specifications for the Spelled out product name:

- [FGR2-IO-IOE Specifications \(on page 124\)](#)
- [FGR2-IO-C-U and FGR2-IO-CE-U Specifications \(on page 127\)](#)
- [FGRIO-S Specifications \(on page 130\)](#)
- [I2-IO-C-U Specifications \(on page 132\)](#)
- [FGR3-IO-IOE Specifications \(on page 134\)](#)
- [FGR3-IO-C-U Specifications \(on page 137\)](#)

## 8.1 FGR2-IO-IOE Specifications

Specifications may change at any time without notice. For the most up-to-date specifications information, see the product's data sheet available at [www.freewave.com](http://www.freewave.com).

<b>FGR2-IO-IOE Specifications</b>	
<b>Transmitter</b>	
Frequency Range	902 – 928 MHz
Output Power	1 W
Range, Line of Sight (LOS)	60 miles with clear LOS
Modulation	2 level GFSK, 115.2 Kbps
Occupied Bandwidth	230 kHz
Hopping Patterns	15 per Band, 105 total, user selectable
Hopping Channels	50 to 112, user selectable
Hopping Bands	7, user selectable
RF Connector	Type SMA, TNC (Female connectors)
<b>Receiver</b>	
Sensitivity (board-level only)	-107 dBm @ 115.2 kbps for BER $10^{-4}$ -104 dBm @ 153.6 kbps for BER $10^{-4}$
Selectivity	IF Selectivity 40 dB at $f_c \pm 460$ kHz RF Selectivity > 60 dB
System Gain	137 dB
<b>Data Transmission<sup>(1)</sup></b>	
Error Detection	32 bit CRC, retransmit on error
Link Throughput	115.2 Kbps
Data Interface	Serial
Protocol	RS-232/422/485, 1200 baud – 115.2 Kbaud
Data Connector	10-pin header with locking ramp 0.1 inch spacing, power/data connector
<b>Input</b>	<b>Modbus</b>
2: Precision AIs (20 bits, 0-5.625 V, 0.1% FS Accuracy), also act as exact-threshold DIs	x
2: DIs with counters (32 bits, 1000 Hz), also act as aux. AIs (10 bits, 0-3.5 V, 0.25% FS Accuracy)	x
1: DI with pull down resistor (5 KOhm)	x

<b>FGR2-IO-IOE Specifications</b>				
1: DI with pulsed 50 mA pull-up for long-lines or high noise		x		
<b>Output</b>				
2: High Current (2 A sink to GND) DOs with current sensing and self-resetting protection		x		
1: AO - 15 bits, 4-20mA, 0.1% FS Accuracy, also acts as 50mA sensor power or DI		x		
1: AO - 16 bits, 4-20mA, 0.1% FS Accuracy		x		
<b>Internal</b>				
1: Battery / Supply Voltage - 10 bits, 0-30 V, 1% FS Accuracy		x		
1: Radio Temperature - 1° C units, -40° C to +70° C, 4° C accuracy		x		
Expandable I/O Stack up to 15 Expansion Modules		x		
<b>Diagnostics Interface</b>				
Connector	Separate 20-pin PCB header			
<b>Power Requirements</b>				
Operating Voltage	+6.0 to +30.0 VDC			
Average Current (mA) (currents shown with no AO connections made)	Mode	+6.0 VDC	+12.0 VDC	+30.0 VDC
	Transmit	+6.0 VDC: 410 mA	+12.0 VDC: 198 mA	+30.0 VDC: 86 mA
	Receive	+6.0 VDC: 83 mA	+12.0 VDC: 45 mA	+30.0 VDC: 24 mA
	Idle-Linked Slave	+6.0 VDC: 76 mA	+12.0 VDC: 42 mA	+30.0 VDC: 21 mA
	Idle-Linked Master	+6.0 VDC: 98 mA	+12.0 VDC: 51 mA	+30.0 VDC: 24 mA
	Modbus Linked Lowpower = 4	+6.0 VDC: 71 mA	+12.0 VDC: 39 mA	+30.0 VDC: 20 mA
<b>Product Safety</b>				
Standards	EN 60079-0:2012 + A11:2013 and EN 60079-15:2010			
Labeling Information	 II 3 G Ex nA IIC Gc <b>DEMKO 14 ATEX 1209313U</b>			
<b>General Information</b>				
Operating Temperature Range	-40°C to +75°C			

## 8. Specifications

<b>FGR2-IO-IOE Specifications</b>	
	Every radio 100% factory tested over this range.
Dimensions	Enclosure: 181 L x 80 W x 38 H (mm)
Weight	Enclosure: 163 g
Humidity	0 to 95% non-condensing

- (1) Data port not operative in wire replacement mode.
- (2) DIs operative, but there are no counters in Wire Replacement mode.
- (3) No current sensing in wire.

## 8.2 FGR2-IOS-C-U and FGR2-IOS-CE-U Specifications

Specifications may change at any time without notice. For the most up-to-date specifications information, see the product's data sheet available at [www.freewave.com](http://www.freewave.com).

FGR2-IOS-C-U and FGR2-IOS-CE-U Specifications	
<b>Transmitter</b>	
Frequency Range	902 – 928 MHz
Output Power	1 W
Range, Line of Sight (LOS)	60 miles with clear LOS
Modulation	2 level GFSK, 115.2 Kbps
Occupied Bandwidth	230 kHz
Hopping Patterns	15 per Band, 105 total, user selectable
Hopping Channels	50 to 112, user selectable
Hopping Bands	7, user selectable
RF Connector	Type SMA, TNC (Female connectors)
<b>Receiver</b>	
Sensitivity (board-level only)	-107 dBm @ 115.2 kbps for BER $10^{-4}$ -104 dBm @ 153.6 kbps for BER $10^{-4}$
Selectivity	IF Selectivity 40 dB at fc +/- 460 kHz RF Selectivity > 60 dB
System Gain	137 dB
<b>Data Transmission<sup>(1)</sup></b>	
Error Detection	32 bit CRC, retransmit on error
Link Throughput	115.2 Kbps
Data Interface	Serial
Protocol	RS-232/422/485, 300 baud – 115.2 Kbaud
Data Connector	10-pin header with locking ramp 0.1 inch spacing, power/data connector
<b>Input</b>	<b>Modbus</b>
2: Precision AIs (20 bits, 0-5.625 V, 0.1% FS Accuracy), also act as exact-threshold DIs	x
2: Precision AIs (20 bits, 0-5.625 V, 0.1% FS Accuracy), also act as exact-threshold DIs	x

## 8. Specifications

<b>FGR2-IOS-C-U and FGR2-IOS-CE-U Specifications</b>				
2: Precision AIs (20 bits, 0-5.625 V, 0.1% FS Accuracy), also act as exact-threshold DIs		X		
2: Precision AIs (20 bits, 0-5.625 V, 0.1% FS Accuracy), also act as exact-threshold DIs		x		
<b>Output</b>				
2: High Current (2 A sink to GND) DOs with current sensing and self-resetting protection		x		
1: AO - 15 bits, 4-20mA, 0.1% FS Accuracy, also acts as 50mA sensor power or DI		x		
1: AO - 16 bits, 4-20mA, 0.1% FS Accuracy		x		
<b>Internal</b>				
1: Battery / Supply Voltage - 10 bits, 0-30 V, 1% FS Accuracy		x		
1: Radio Temperature - 1° C units, -40° C to +70° C, 4° C accuracy		x		
<b>Diagnostics Interface</b>				
Connector	Separate 20-pin PCB header			
<b>Power Requirements</b>				
Operating Voltage	+6.0 to +30.0 VDC			
Average Current (mA) (currents shown with no AO connections made)	Mode	+6.0 VDC	+12.0 VDC	+30.0 VDC
	Transmit	800	380	170
	Receive	90	55	40
	Idle	24	16	8
	Modbus Linked Lowpower = 4	+6.0 VDC: 71 mA	+12.0 VDC: 39 mA	+30.0 VDC: 20 mA
	Wire Replacement Linked	30	15	8
<b>Product Safety</b>				
Standards	EN 60079-0:2012 + A11:2013 and EN 60079-15:2010			
Labeling Information	 II 3 G Ex nA IIC Gc <b>DEMKO 14 ATEX 1209313U</b>			



<b>FGR2-IOS-C-U and FGR2-IOS-CE-U Specifications</b>	
<b>General Information</b>	
Operating Temperature Range	-40°C to +75°C Every radio 100% factory tested over this range.
Dimensions	Board Level: 127 L x 62 W x 16 H (mm) Enclosure: 173 L x 96 W x 35 H (mm)
Weight	Board Level: 60 g Enclosure: 509 g
Humidity	0 to 95% non-condensing

- (1) Data port not operative in wire replacement mode.
- (2) DIs operative, but there are no counters in Wire Replacement mode.
- (3) No current sensing in wire.

## 8.3 FGRIO-S Specifications

**Note:** FGRIO-S models are no longer available for purchase from FreeWave.

**FreeWave Recommends:** The FGR3-IO-S-C-U or FGR3-IO-IOE as an over-the-air backwards-compatible replacement.

Specifications may change at any time without notice. For the most up-to-date specifications information, see the product's data sheet available at [www.freewave.com](http://www.freewave.com).

FGRIO-S Specifications	
<b>Radio</b>	
Frequency Range	902 – 928 MHz
Output Power	100 mW
Range, Line-of-sight	2 miles
Modulation	2 level GFSK
Occupied Bandwidth	230 kHz
Hopping Patterns	15, user selectable
Hopping Channels	50 to 112, user selectable
Hopping Bands	7, user selectable
RF Connector	SMA female
<b>Receiver</b>	
Sensitivity	-98 dBm at $10^{-6}$ BER -100 dBm at $10^{-4}$ BER
Selectivity	20 dB at $f_c \pm 115$ kHz 60 dB at $f_c \pm 145$ kHz
System Gain	130 dB
<b>Data Transmission</b>	
Error Detection	32 bit CRC, retransmit on error
Link Throughput	115.2 Kbps
Data Interface	Serial
Protocol	RS-232/422/485, 300 baud – 115.2 Kbaud
Data Connector	10-pin header
<b>Analog Inputs</b>	
Number of Inputs	2
Accuracy, Resolution	$\pm 0.1\%$ , 16 bit

Mode	+6.0 VDC	+12.0 VDC	+20.0 VDC
Transmit	120	68	48
Receive	68	38	28
Linked	12	7	6

<b>FGRIO-S Specifications</b>	
Input Range	0.2 – 5.62 V, 94 K $\Omega$ input resistance
<b>Digital Inputs</b>	
Number of Inputs	2
Input Pull-up	10 K $\Omega$ to 3.3 V
Input Pull-down	10 K $\Omega$ to GND
Input Connector	Mini Phoenix (3.55 mm)
Slave Input to Master Output Delay	1 second maximum
Signal Input Voltage Maximum	$\pm$ 20 V
Maximum Count Size & Rate	32 bits, 1000 Hz
AI of DI Accuracy, Resolution	$\pm$ 0.25%, 10 bit
AI of DI Input Range	0 – 3.5 V
<b>Digital Output</b>	
Number of Outputs	2
Current Rating	2 Amps maximum
Voltage Rating	Lesser of: 20 V or the radio supply voltage
<b>Diagnostic Interface</b>	
Connector	Separate 20-pin PCB header
<b>Power Requirements</b>	
Operating Voltage	+6.0 to +20.0 V DC
<b>General Information</b>	
Operating Temperature Range	-40° C to +75° C
Dimensions	138 mm L x 76 mm W x 12 mm H
Weight	58 g
Humidity	0 to 95% non-condensing

## 8.4 I2-IO-C-U Specifications

Specifications may change at any time without notice. For the most up-to-date specifications information, see the product's data sheet available at [www.freewave.com](http://www.freewave.com).

I2-IO-C-U Specifications		
<b>Transmitter</b>		
Frequency Range	2.4 - 2.483 GHz (FHSS)	
Output Power	5 mW to 500 mW	
Range, Line of Sight (LOS)	20 miles with clear LOS	
Modulation	2 level GFSK, 115.2 Kbps	
Occupied Bandwidth	230 kHz	
Hopping Patterns	15 per Band, 105 total, user selectable	
Hopping Channels	50 to 80, user selectable	
Hopping Bands	7, user selectable	
RF Connector	Type SMA, TNC (Female connectors)	
<b>Receiver</b>		
Sensitivity (board-level only)	-105 dBm at $10^{-6}$ BER -107 dBm at $10^{-4}$ BER	
Selectivity	TBD	
System Gain	134 dB	
<b>Data Transmission</b>		
Error Detection	32 bit CRC, retransmit on error	
Link Throughput	115.2 Kbps	
Data Interface	Serial	
Protocol	RS-232/422/485, 300 baud – 115.2 Kbaud	
Data Connector	10-pin header with locking ramp 0.1 inch spacing, power/data connector	
<b>Input</b>	<b>Modbus</b>	<b>Wire Replacement</b>
2: Precision AIs (20 bits, 0-5.625 V, 0.1% FS Accuracy), also act as exact-threshold DIs	x	x
2: DIs with counters (32 bits, 1000 Hz), also act as aux. AI's (10 bits, 0-3.5 V, 0.25% FS Accuracy)	x	(2)
1: DI with pull down resistor (5 KOhm)	x	
1: DI with pulsed 50 mA pull-up for long-lines or high noise	x	

<b>I2-IO5-C-U Specifications</b>																											
<b>Output</b>																											
2: High Current (2 A sink to GND) DO's with current sensing and self-resetting protection	x		X(3)																								
1: AO - 15 bits, 4-20mA, 0.1% FS Accuracy, also acts as 50mA sensor power or DI	x																										
1: AO - 16 bits, 4-20mA, 0.1% FS Accuracy	x																										
<b>Internal</b>																											
1: Battery / Supply Voltage - 10 bits, 0-30 V, 1% FS Accuracy	x																										
1: Radio Temperature - 1° C units, -40° C to +70° C, 4° C accuracy	x																										
<b>Diagnostics Interface</b>																											
Connector	Separate 20-pin PCB header																										
<b>Power Requirements</b>																											
Operating Voltage	+6.0 to +30.0 VDC																										
Average Current (mA)	<table border="1"> <thead> <tr> <th>Mode</th> <th>+6.0 VDC</th> <th>+12.0 VDC</th> <th>+30.0 VDC</th> </tr> </thead> <tbody> <tr> <td>Transmit</td> <td>375</td> <td>295</td> <td>140</td> </tr> <tr> <td>Receive</td> <td>120</td> <td>80</td> <td>51</td> </tr> <tr> <td>Idle</td> <td>9</td> <td>5</td> <td>3</td> </tr> <tr> <td>Modbus Linked Low power = 4</td> <td>10</td> <td>7</td> <td>5</td> </tr> <tr> <td>Wire Replacement Linked</td> <td>30</td> <td>15</td> <td>8</td> </tr> </tbody> </table>			Mode	+6.0 VDC	+12.0 VDC	+30.0 VDC	Transmit	375	295	140	Receive	120	80	51	Idle	9	5	3	Modbus Linked Low power = 4	10	7	5	Wire Replacement Linked	30	15	8
Mode	+6.0 VDC	+12.0 VDC	+30.0 VDC																								
Transmit	375	295	140																								
Receive	120	80	51																								
Idle	9	5	3																								
Modbus Linked Low power = 4	10	7	5																								
Wire Replacement Linked	30	15	8																								
<b>General Information</b>																											
Operating Temperature Range	-40°C to +75°C. Every radio 100% factory tested over this range.																										
Dimensions	Board Level: 127 L x 62 W x 16 H (mm) Enclosure: 173 L x 96 W x 35 H (mm)																										
Weight	Board Level: 58 g Enclosure: 1.2 lbs																										
Humidity	0 to 95% non-condensing																										

## 8.5 FGR3-IO-IOE Specifications

Specifications may change at any time without notice. For the most up-to-date specifications information, see the product's data sheet available at [www.freewave.com](http://www.freewave.com).

<b>FGR3-IO-IOE Specifications</b>	
<b>Transmitter</b>	
Frequency Range	902 – 928 MHz
Output Power	1 W
Range, Line of Sight (LOS)	60 miles with clear LOS
Modulation	2 level GFSK, 115.2 Kbps
Occupied Bandwidth	230 kHz
Hopping Patterns	15 per Band, 105 total, user selectable
Hopping Channels	50 to 112, user selectable
Hopping Bands	7, user selectable
RF Connector	Type SMA, TNC (Female connectors)
<b>Receiver</b>	
Sensitivity (board-level only)	-107 dBm @ 115.2 kbps for BER $10^{-4}$ -104 dBm @ 153.6 kbps for BER $10^{-4}$
Selectivity	IF Selectivity 40 dB at $f_c \pm 460$ kHz RF Selectivity > 60 dB
System Gain	137 dB
<b>Data Transmission<sup>(1)</sup></b>	
Error Detection	32 bit CRC, retransmit on error
Link Throughput	115.2 Kbps
Data Interface	Serial
Protocol	RS-232/422/485, 1200 baud – 115.2 Kbaud
Data Connector	10-pin header with locking ramp 0.1 inch spacing, power/data connector
<b>Input</b>	<b>Modbus</b>
2: Precision AIs (20 bits, 0-5.625 V, 0.1% FS Accuracy), also act as exact-threshold DIs	x
2: DIs with counters (32 bits, 1000 Hz), also act as aux. AIs (10 bits, 0-3.5 V, 0.25% FS Accuracy)	x
1: DI with pull down resistor (5 KOhm)	x

<b>FGR3-IO-IOE Specifications</b>				
1: DI with pulsed 50 mA pull-up for long-lines or high noise		x		
<b>Output</b>				
2: High Current (2 A sink to GND) DOs with current sensing and self-resetting protection		x		
1: AO - 15 bits, 4-20mA, 0.1% FS Accuracy, also acts as 50mA sensor power or DI		x		
1: AO - 16 bits, 4-20mA, 0.1% FS Accuracy		x		
<b>Internal</b>				
1: Battery / Supply Voltage - 10 bits, 0-30 V, 1% FS Accuracy		x		
1: Radio Temperature - 1° C units, -40° C to +70° C, 4° C accuracy		x		
Expandable I/O Stack up to 15 Expansion Modules		x		
<b>Diagnostics Interface</b>				
Connector	Separate 20-pin PCB header			
<b>Power Requirements</b>				
Operating Voltage	+6.0 to +30.0 VDC			
Average Current (mA) (currents shown with no AO connections made)	Mode	+6.0 VDC	+12.0 VDC	+30.0 VDC
	Transmit	+6.0 VDC: 410 mA	+12.0 VDC: 198 mA	+30.0 VDC: 86 mA
	Receive	+6.0 VDC: 83 mA	+12.0 VDC: 45 mA	+30.0 VDC: 24 mA
	Idle-Linked Slave	+6.0 VDC: 76 mA	+12.0 VDC: 42 mA	+30.0 VDC: 21 mA
	Idle-Linked Master	+6.0 VDC: 98 mA	+12.0 VDC: 51 mA	+30.0 VDC: 24 mA
	Modbus Linked Lowpower = 4	+6.0 VDC: 71 mA	+12.0 VDC: 39 mA	+30.0 VDC: 20 mA
<b>Product Safety</b>				
Standards	EN 60079-0:2012 + A11:2013 and EN 60079-15:2010			
Labeling Information	 II 3 G Ex nA IIC Gc <b>DEMKO 14 ATEX 1209313U</b>			
<b>General Information</b>				
Operating Temperature Range	-40°C to +75°C			

## 8. Specifications

<b>FGR3-IO-IOE Specifications</b>	
	Every radio 100% factory tested over this range.
Dimensions	Enclosure: 181 L x 80 W x 38 H (mm)
Weight	Enclosure: 163 g
Humidity	0 to 95% non-condensing

- (1) Data port not operative in wire replacement mode.
- (2) DIs operative, but there are no counters in Wire Replacement mode.
- (3) No current sensing in wire.



## 8.6 FGR3-IOS-C-U Specifications

Specifications may change at any time without notice. For the most up-to-date specifications information, see the product's data sheet available at [www.freewave.com](http://www.freewave.com).

FGR3-IOS-C-U Specifications	
<b>Transmitter</b>	
Frequency Range	902 – 928 MHz
Output Power	1 W
Range, Line of Sight (LOS)	60 miles with clear LOS
Modulation	2 level GFSK, 115.2 Kbps
Occupied Bandwidth	230 kHz
Hopping Patterns	15 per Band, 105 total, user selectable
Hopping Channels	50 to 112, user selectable
Hopping Bands	7, user selectable
RF Connector	Type SMA, TNC (Female connectors)
<b>Receiver</b>	
Sensitivity (board-level only)	-107 dBm @ 115.2 kbps for BER $10^{-4}$ -104 dBm @ 153.6 kbps for BER $10^{-4}$
Selectivity	IF Selectivity 40 dB at fc +/- 460 kHz RF Selectivity > 60 dB
System Gain	137 dB
<b>Data Transmission<sup>(1)</sup></b>	
Error Detection	32 bit CRC, retransmit on error
Link Throughput	115.2 Kbps
Data Interface	Serial
Protocol	RS-232/422/485, 300 baud – 115.2 Kbaud
Data Connector	10-pin header with locking ramp 0.1 inch spacing, power/data connector
<b>Input</b>	<b>Modbus</b>
2: Precision AIs (20 bits, 0-5.625 V, 0.1% FS Accuracy), also act as exact-threshold DIs	x
2: Precision AIs (20 bits, 0-5.625 V, 0.1% FS Accuracy), also act as exact-threshold DIs	x

## 8. Specifications

<b>FGR3-IOS-C-U Specifications</b>				
2: Precision AIs (20 bits, 0-5.625 V, 0.1% FS Accuracy), also act as exact-threshold DIs		x		
2: Precision AIs (20 bits, 0-5.625 V, 0.1% FS Accuracy), also act as exact-threshold DIs		x		
<b>Output</b>				
2: High Current (2 A sink to GND) DOs with current sensing and self-resetting protection		x		
1: AO - 15 bits, 4-20mA, 0.1% FS Accuracy, also acts as 50mA sensor power or DI		x		
1: AO - 16 bits, 4-20mA, 0.1% FS Accuracy		x		
<b>Internal</b>				
1: Battery / Supply Voltage - 10 bits, 0-30 V, 1% FS Accuracy		x		
1: Radio Temperature - 1° C units, -40° C to +70° C, 4° C accuracy		x		
<b>Diagnostics Interface</b>				
Connector	Separate 20-pin PCB header			
<b>Power Requirements</b>				
Operating Voltage	+6.0 to +30.0 VDC			
Average Current (mA) (currents shown with no AO connections made)	Mode	+6.0 VDC	+12.0 VDC	+30.0 VDC
	Transmit	800	380	170
	Receive	90	55	40
	Idle	24	16	8
	Modbus Linked Lowpower = 4	+6.0 VDC: 71 mA	+12.0 VDC: 39 mA	+30.0 VDC: 20 mA
	Wire Replacement Linked	30	15	8
<b>Product Safety</b>				
Standards	EN 60079-0:2012 + A11:2013 and EN 60079-15:2010			
Labeling Information	 II 3 G Ex nA IIC Gc <b>DEMKO 14 ATEX 1209313U</b>			

<b>FGR3-IOS-C-U Specifications</b>	
<b>General Information</b>	
Operating Temperature Range	-40°C to +75°C Every radio 100% factory tested over this range.
Dimensions	Board Level: 127 L x 62 W x 16 H (mm) Enclosure: 173 L x 96 W x 35 H (mm)
Weight	Board Level: 60 g Enclosure: 509 g
Humidity	0 to 95% non-condensing

- (1) Data port not operative in wire replacement mode.
- (2) DIs operative, but there are no counters in Wire Replacement mode.
- (3) No current sensing in wire.

## 9. Ports

---

These are the ports for the Spelled out product name:

- [FGR3-IO-IOE Ports \(on page 141\)](#)
- [FGR2-IO-IOE Ports \(on page 141\)](#)
- [FGR2-IO-CE-U Ports \(on page 142\)](#)
- [FGR3-IO-C-U Ports \(on page 143\)](#)
- [FGR2-IO-C-U Ports \(on page 144\)](#)
- [FGRIO-S Ports \(on page 145\)](#)

### 9.1 FGR2-IO-IOE and FGR3-IO-IOE Ports

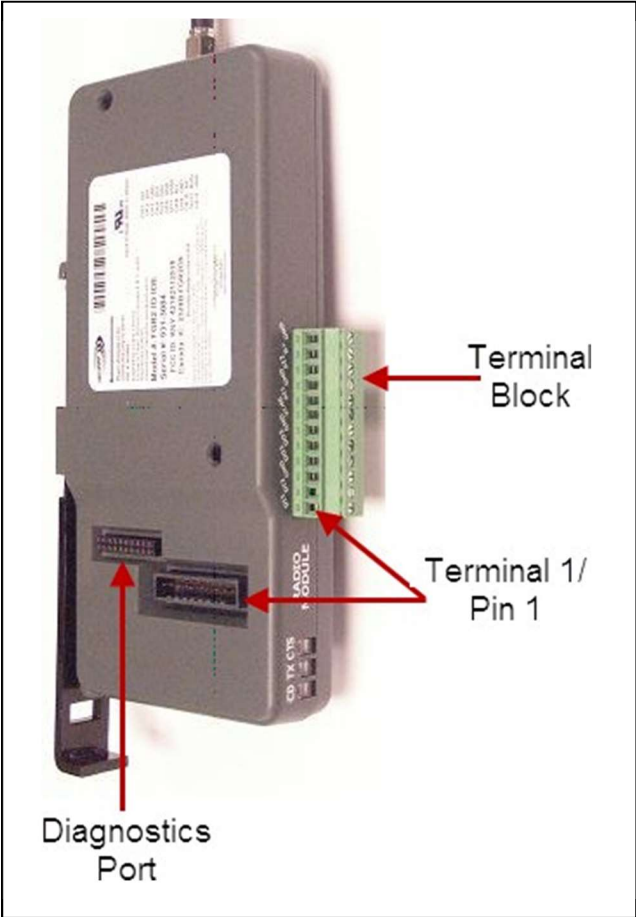

## 9.2 FGR2-IOS-CE-U Ports

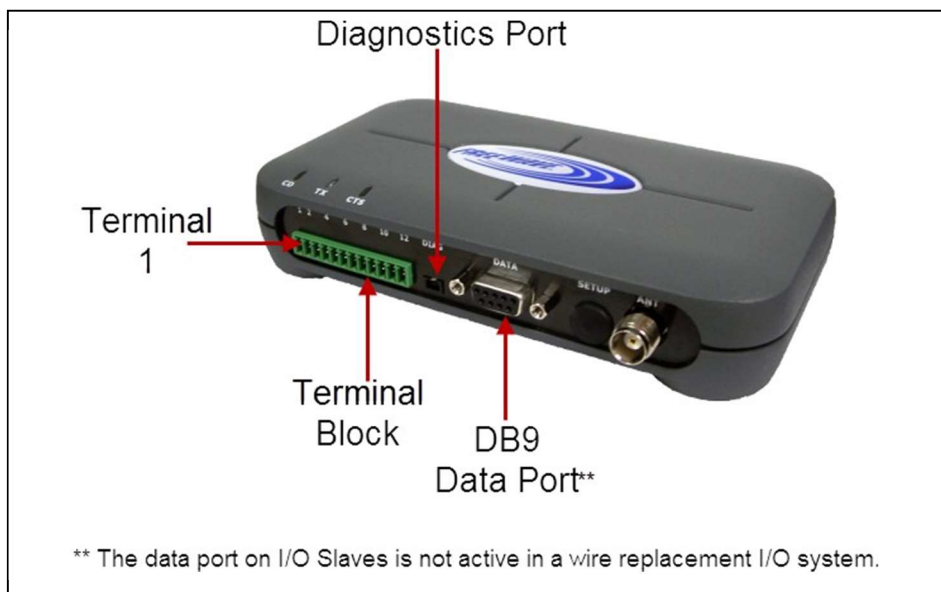

### 9.3 FGR3-IOS-C-U Ports

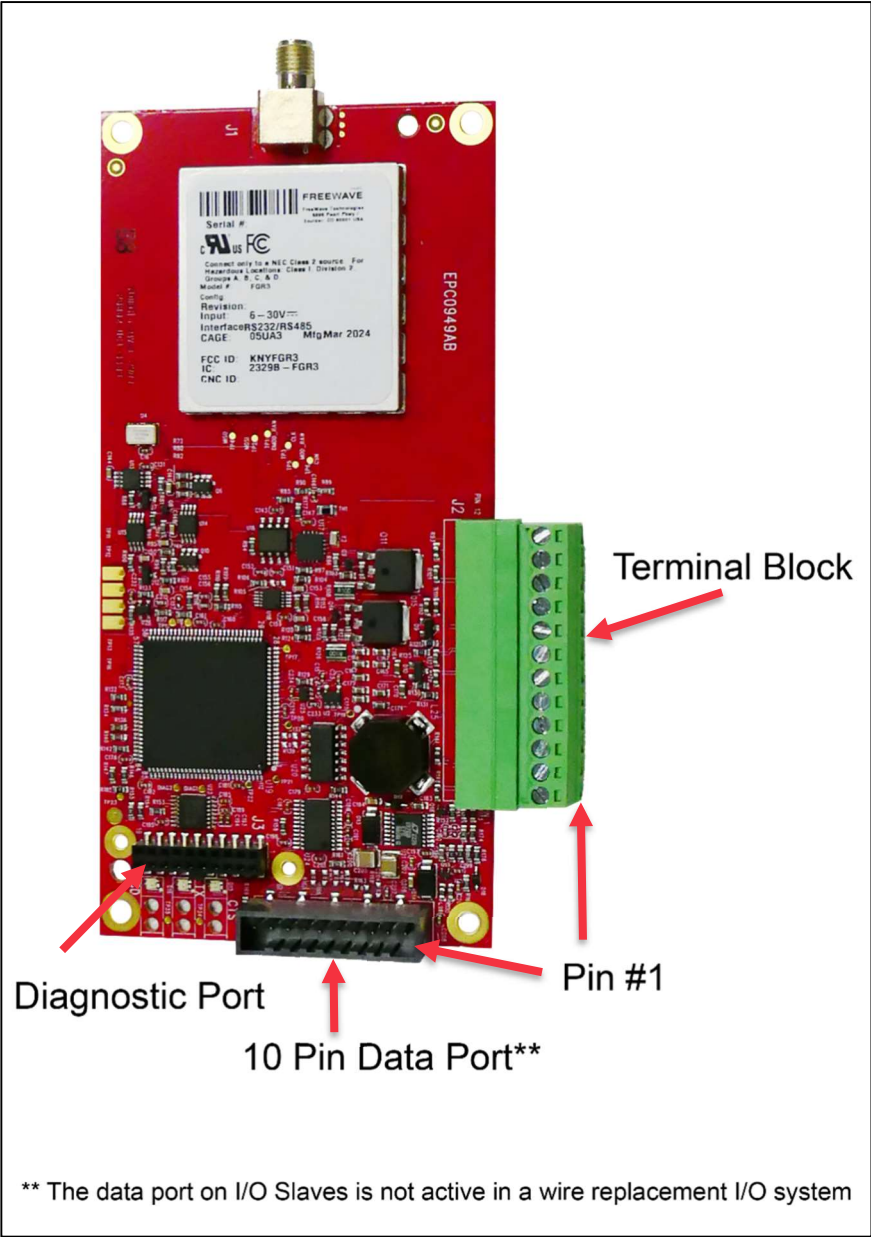

## 9.4 FGR2-IOS-C-U Ports

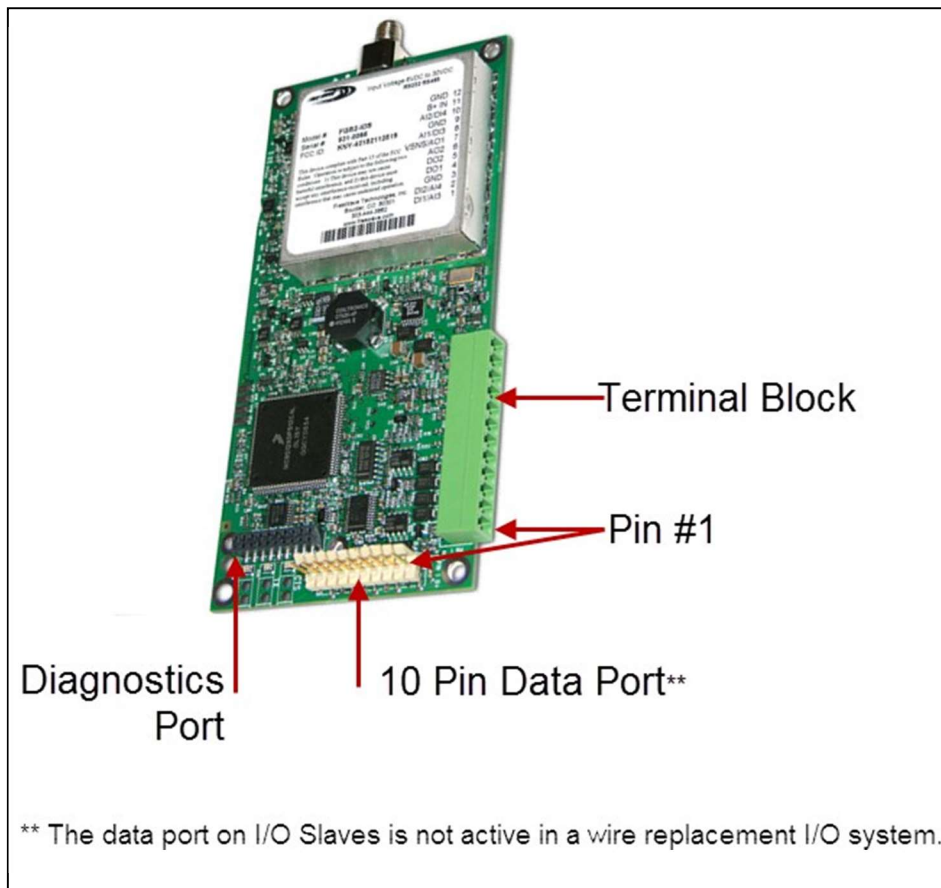



### 9.5 FGRIIO-S Ports

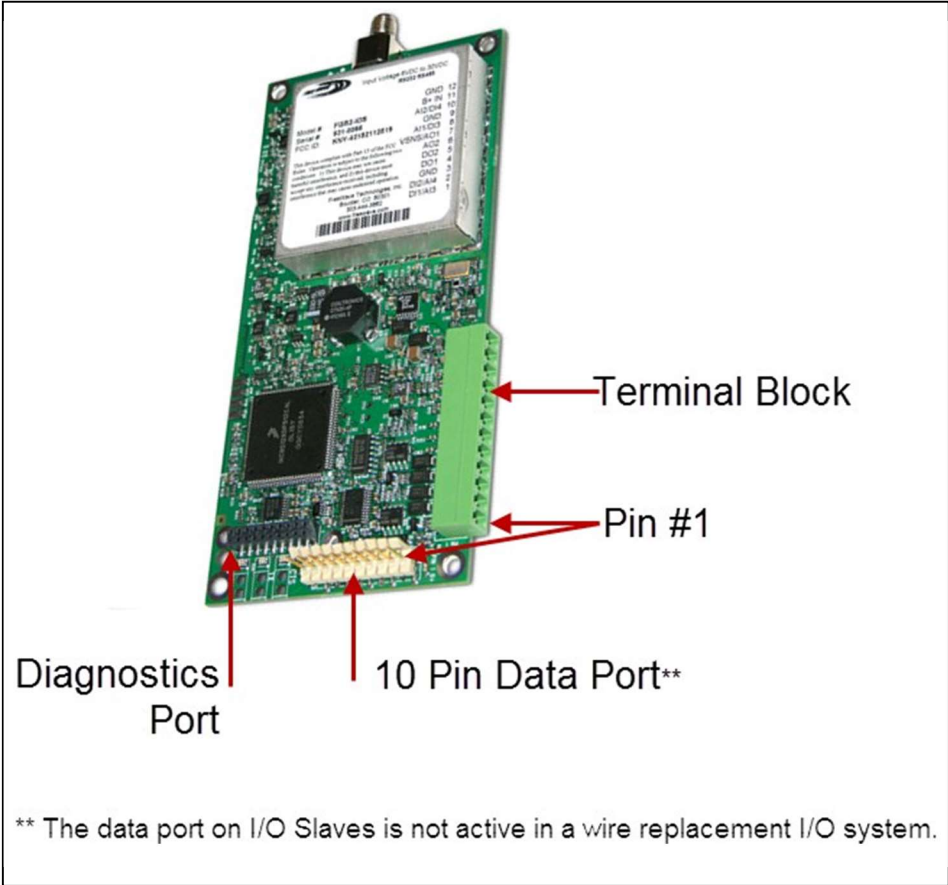



## **10. Terminal Block Layouts**

These are the terminal block layouts for the Spelled out product name:

- [FGR3-IO-IOE, FGR3-IO-S-C-U, and FGRIO-S Terminal Block Layouts \(on page 148\)](#)

## 10.1 FGR3-IOS-C-U, FGRIO-S, FGR2-IOS-C-U, FGR2-IOS-CE-U, I2-IOS, FGR3-IO-IOE, and FGR2-IO-IOE Terminal Block Layouts

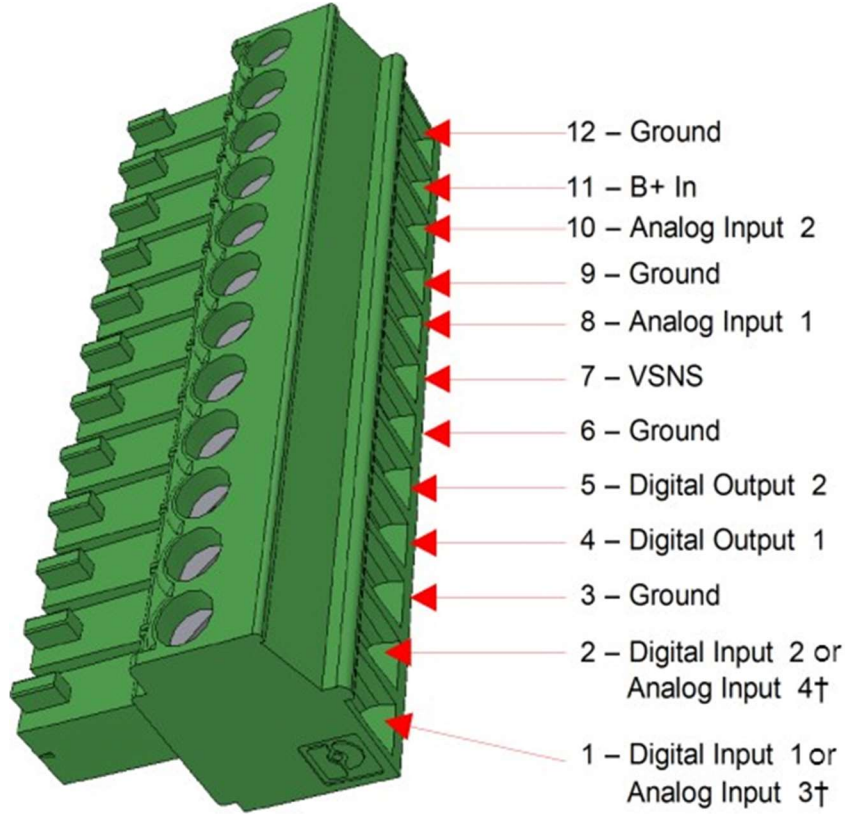

† Analog Inputs 3 and 4 are 0 to +3.3 VDC inputs. See wiring diagrams in this document for details.



## Appendix A: DI of AI1 Pull-Up Resistor Network

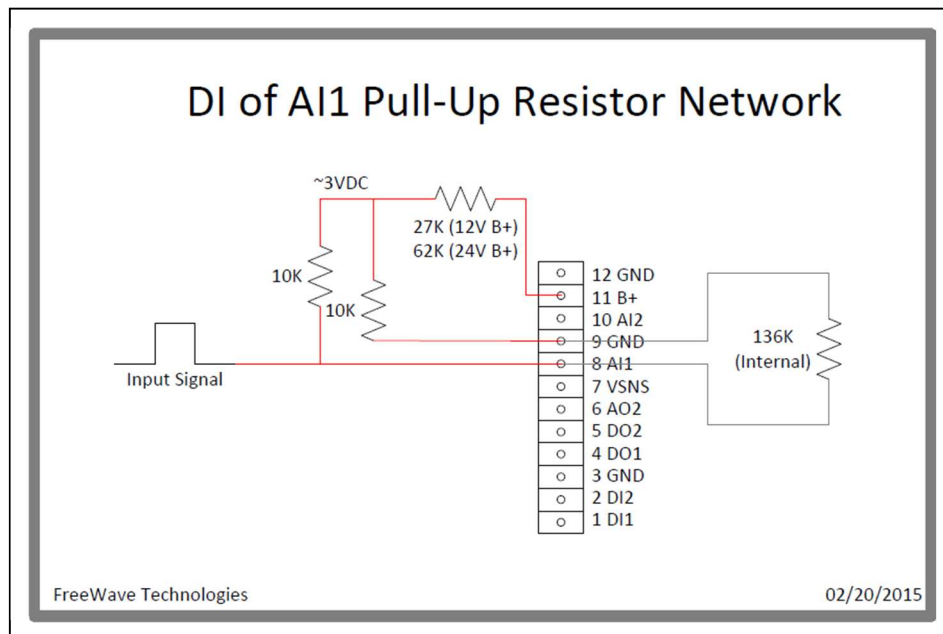



## **Appendix B: Troubleshooting Terminal Emulators**

These are some common issues encountered while using terminal emulators

Nothing displays on the screen after placing the radio into Setup mode.

This usually indicates one of two things; either the wrong COM port is selected or a null modem cable is being used.

Change the COM port, verify the cable, and attempt to connect again.

Unreadable characters display on the screen after placing the radio into Setup mode.

This typically indicates a baud rate mismatch.



**Tip:** If the radio was previously configured, you could be using the wrong port to access the **Setup** menu.

**Note:** For more information, see [Setup Port on page 33](#). Try connecting to the other port.

- Unreadable characters before grounding the pin indicates Diagnostics is enabled and the terminal emulator is connected to the Diagnostics pins.
- Update the terminal emulator's baud rate to 19200 and reconnect to the radio.

The Setup menu displays on the screen, but nothing happens when keys on the keyboard are pressed.

This usually indicates flow control is turned on in a three-wire connection (Rx, Tx, and Gnd).

Update the terminal emulator's flow control setting to None and reconnect to the radio.

A connection exists, the terminal emulator is receiving data, and some data is correct, but the remaining data is in unrecognizable characters.



This usually indicates a parity mismatch.

Ensure that the parity of the radio and the parity of the emulator are set the same.

---

## Appendix C: Frequently Asked Questions

**Q:** Can I/O be used with a 1 Watt radio?

**A:** The FGRIO-M functions as a standard 900 MHz 1 Watt serial radio with a 60 mile line-of-sight range.

The FGRIO-S functions as an FGR Short Range radio with a 2 mile line-of-sight range.

The FGR2-IO-S-C-U and FGR2-IO-S-CE-U function as FGR2 radios with a 60 mile line-of-sight range.

**Q:** Can the I/O radios be repeated through our other radios to extend the range?

**A:** From the I/O Slave to the I/O Master, you cannot use a Repeater. When the I/O Master is integrated into a standard serial network, you can use Repeaters between the I/O Master and the Serial Master as they already are in existing FreeWave networks. The I/O Master cannot function as a Slave/Repeater.

**Q:** Can the I/O Master operate as Slave/Repeater in the overall network?

**A:** The IO Master currently does not have the capability to operate as a Slave/Repeater. It does function as the Master to the I/O Slave, and as a MultiPoint Slave to the rest of the network.

**Q:** Can data be sent directly from the I/O Slave to the Master of the serial network?

**A:** No. The wire replacement system functions as wire replacement only. The IO Slave's serial ports are inactive and do not have the capability of transmitting data directly to the Master of a serial network.

**Q:** What timing issues does a wire replacement system introduce?

**A:** Although a wire replacement system mimics a wired connection, the electronics and communication heartbeat do cause some signal delay. The worst case delay for digital signals in either direction and in the Sensor Power command from I/O Master to IO Slave is 167 ms, assuming a robust link. Worst case delay from I/O Master Sensor Power assertion to I/O Master Analog Output refresh is 700 ms.

